



Screw Pumps with Magnetic Coupling.

Marine applications.



Green Shipping Technology.

KRAL innovations make an important contribution towards environmental protection.

KRAL screw pumps with magnetic coupling yield decisive advantages when used in the fuel supply systems of ships. These include lower lifecycle costs and significantly higher operational reliability.

Hermetically sealed KRAL screw pumps with magnetic coupling ensure that neither liquids nor gases are released into the environment. Ship machine rooms stay clean. Fuel doesn't leak into the ocean.



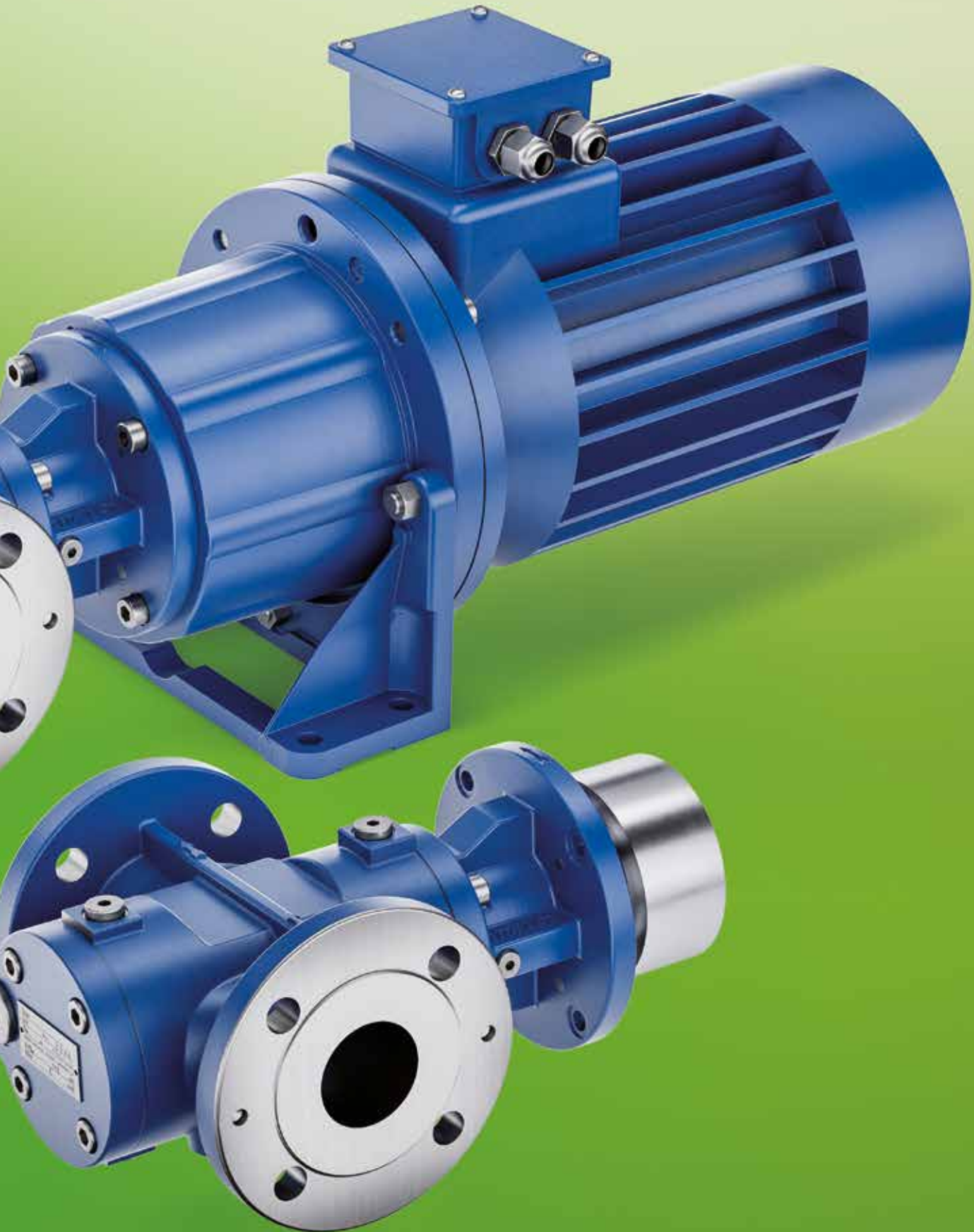

KRAL Screw Pumps With Magnetic Coupling for Marine Applications.

No more problems with mechanical seals.



Green Shipping Technology.

Heavy fuel oil leakage increases the risk for accidents. KRAL screw pumps with magnetic coupling are hermetically sealed. The magnetic couplings never leak. The site stays clean and safe. KRAL pumps with magnetic coupling are an innovative contribution for companies going into 'Green Shipping Technology'.

Prevent pump failure.

The residue of heavy fuel oil can cause a pump to fail. To reduce friction, the faces of the mechanical seal rely upon the pumped liquid for lubrication. The pumped liquid comes in contact with the atmosphere as it moves across the sealing faces. When the liquid is heavy fuel oil, it reacts with the oxygen in the atmosphere to form carbon deposits. These residual deposits build up in the connecting frame causing additional damages to the bearing. The damaged bearings run hot, and the elastomeric coupling may also melt. The pump then fails. KRAL magnetic couplings are hermetically sealed. The fuel does not come into contact with the atmosphere and there is no build-up of residue.

Comparing a magnetic coupling with a mechanical seal.

	Magnetic coupling.	Mechanical seal.
Maintenance interval:	40.000 hours.	10.000 hours.
Temperature:	300 °C.	180 °C.
Easy to convert:	It is quick and easy to convert to KRAL pumps with magnetic coupling. In virtually all cases, the dimensions for the pipework and for installation are the same.	
Costs:	It takes a few years to amortize the additional costs for magnetic coupling.	



Lifecycle cost comparison.

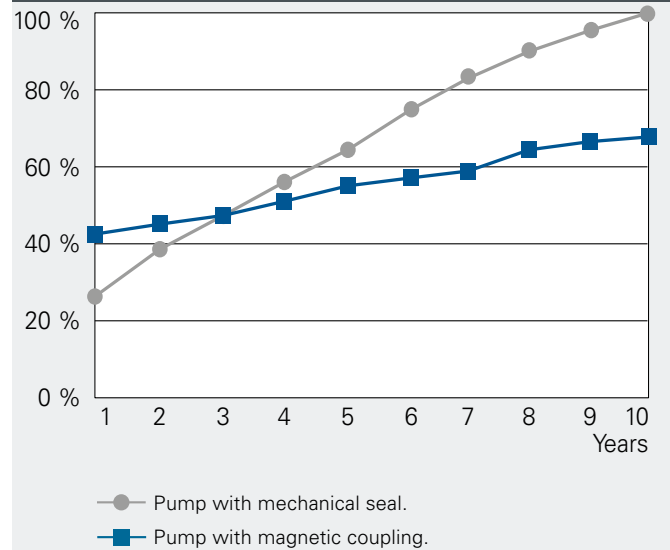

Guarantee on-board safety.

The International Maritime Organization (IMO) requires in its International Convention for the Safety of Life at Sea (SOLAS) the high pressure piping to be jacketed. In opposition to this requirement a leakage in the low pressure piping is tolerated. With the KRAL magnetic coupling, this additional sealing safety can also be transferred to the pumps.

Reduced lifecycle costs.

Spare parts and maintenance costs of mechanical seals increase lifecycle costs. The use of high quality mechanical seals in KRAL screw pumps is the standard. Even when properly applied, mechanical seals are subject to wear. Spare parts and maintenance costs arise. KRAL magnetic couplings are maintenance free. Extended bearing life compared to mechanical sealed pumps. The cost premium of a pump with a magnetic coupling will be typically amortized after only a few years of operation.



Overload protection.

If the operating limits are exceeded, the pump may become damaged. Solids in the fluid can lead to blockade and damage the screw and the housing. In most cases the final manufactured product is not to specification, and the pump must be replaced. If the decoupling is controlled, and the pump stops, the pump and magnetic coupling will suffer no damage. The magnetic coupling can prevent consequential damage.



Engine failure.

If the booster module pumps fail, the diesel engines can cut out and the ship will be unable to maneuver. Up until now, tanks have contained heavy fuel oil of 380 mm²/s, but a trend towards 500 mm²/s fuel is now common. These residual oils must be pre-heated to 180 °C instead of the previous 130 °C. The higher temperature is required to achieve the proper injection viscosity. These high temperatures will damage mechanical seals resulting in pump failure. Magnetically coupled KRAL pumps can be used at temperatures of up to 300 °C.



Prevent pump damage due to incorrect startup.

Running the pump dry will damage the mechanical seal. Each mechanical seal needs positive lubrication. Venting and filling are an essential part of startup. If the system is not vented, the mechanical seal will quickly run dry and may start to leak. KRAL magnetic couplings provide additional security if the pump is not started properly and help to avoid expensive lay-off periods.

KRAL – the marine specialist.

KRAL provides a variety of solutions for marine applications: Magnetically coupled pumps for transfer, circulation pumps in the booster module, pumps with mechanical seals as fuel and lubricating oil pumps in ships packages and magnetically coupled pumps in KRAL stations for marine burners (that also run on heavy fuel oil). In the burner, the magnetic coupling has advantages with regard to temperature stability and the prevention of heavy fuel oil residues. Pumps for hydraulic applications, as for winches, for example.

Innovative Solutions and High Quality.

Optimum safety and significantly reduced operating costs.

■ Advantages.

Compared to other types of pump, KRAL screw pumps provide fast delivery rates in restricted spaces. Delivery is low in pulsation and quiet.

■ High capacity rates.

KRAL pumps with magnetic coupling are available for flow rates up to 3,550 l/min.

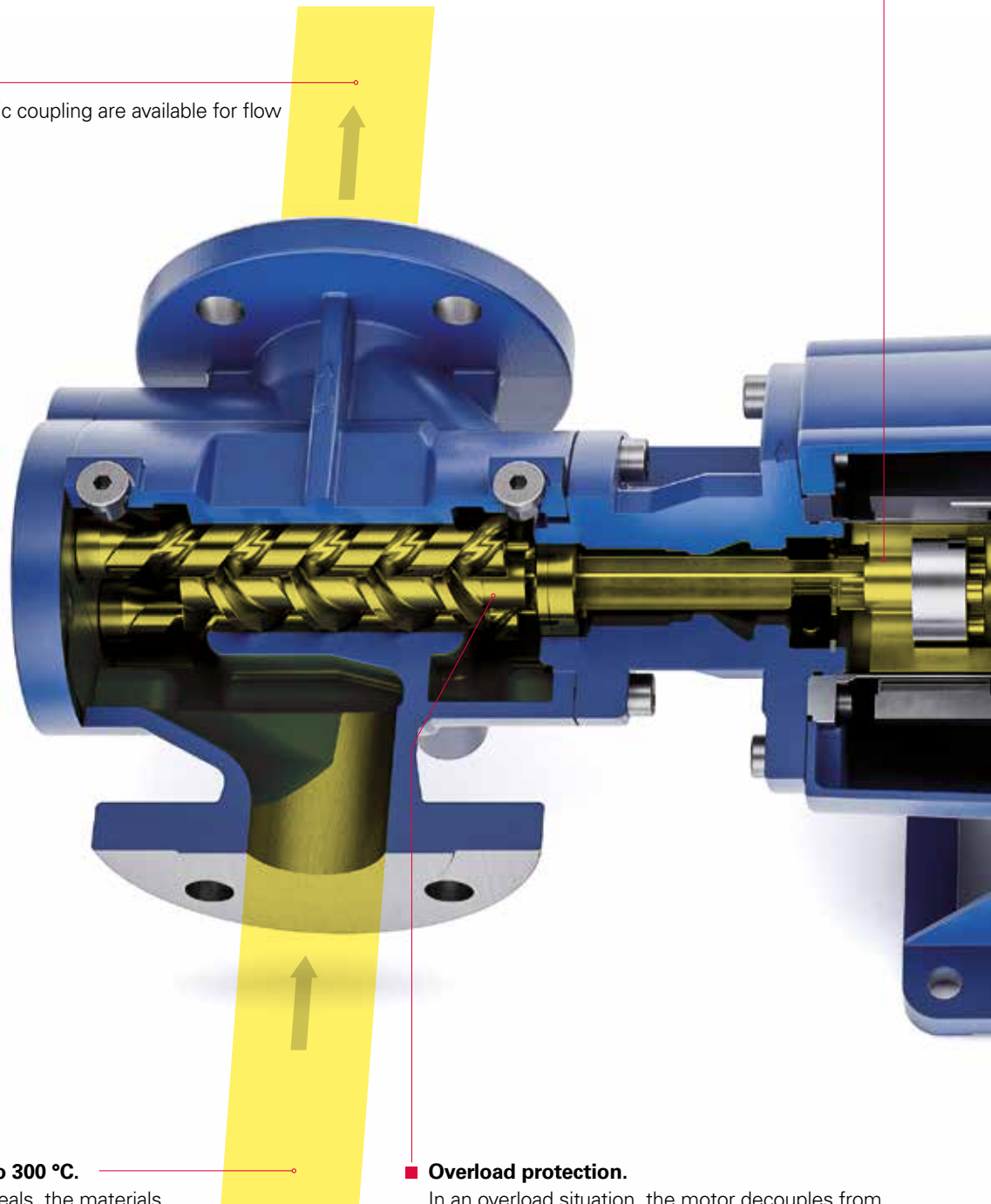

■ Temperature capability to 300 °C.

Compared to mechanical seals, the materials of the magnetic coupling have far better high temperature capability. High viscosity heavy fuel oils that must be preheated to 180 °C can be pumped without risk.

■ Overload protection.

In an overload situation, the motor decouples from driving the pump preventing damage. Once the motor is fully stopped the magnetic coupling will synchronize and the pump can be restarted.

■ **No fuel residue.**

Because the magnetic coupling is sealed, the fuel does not come into contact with the atmosphere. The heavy fuel oil cannot react with the oxygen in the air to form carbon deposits that can damage the ball bearing. This eliminates one of the major causes of pump failure.

■ **Function.**

The rotation of the electric motor is transferred through the magnetic coupling to the pump screws without contact. The electric motor and the pump shaft each have a rotor with several magnets. During operation, the two rotors run in synchronized rotation.

■ **Hermetically sealed.**

The containment can is the sealing element of the KRAL pump. It encapsulates the pump shaft and inner magnet hub. If, in the illustration, you cover the outer rotor on the shaft of the electric motor, the fully-encapsulated nature of the pump becomes apparent.



■ **The magnetic coupling has no wear.**

The magnetic coupling is a contact free component. The pump screws are driven without contact by the magnets on the outer and inner rotor. As there is no friction, there is no wear.

■ **Optimally matched design.**

KRAL has been making magnetically coupled pumps for many years. We manufacture the components to our design standards. This means that the magnetic coupling perfectly matches the requirements of the KRAL screw pump.

Protect life on-board ship – eliminate the risk of fire.

To comply with the provisions of SOLAS, high pressure fuel lines must be jacketed. This precaution prevents the escape of flammable and combustible liquids.

Magnetic couplings provide optimum safety.

To close the safety gap, KRAL recommends pumps with magnetic coupling. The containment can of the magnetic coupling is a totally secure barrier. Fuel cannot escape, as the pump is leak free. The fire risk is effectively reduced.

SOLAS, Part B, Regulation 4.

The International Convention for the Safety of Life at Sea, known as SOLAS, describes the precautionary measures to required to prevent fire and explosion. The important points for the pump environment are Nos. 2.2.5.2 and 2.2.6.1.

2.2.5.2. "External high-pressure fuel delivery lines between the high-pressure fuel pumps and fuel injectors shall be protected with a jacketed piping system capable of containing fuel from a high-pressure line failure. A jacketed pipe incorporates an outer pipe into which the high-pressure fuel pipe is placed, forming a permanent assembly. The jacketed piping system shall include a means for collection of leakages and arrangements shall be provided with an alarm in case of a fuel line failure."

2.2.6.1. "Surfaces with temperatures above 220 °C which may be impinged as a result of a fuel system failure shall be properly insulated."

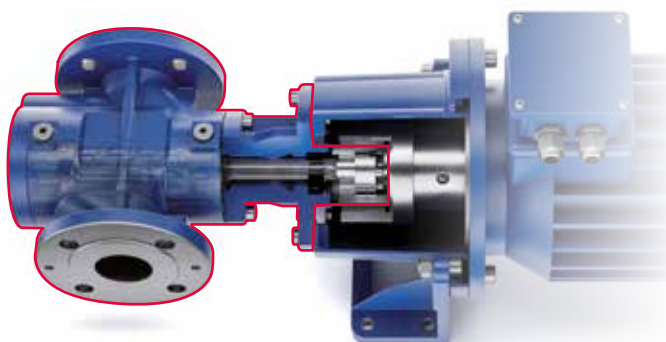

Advantage:



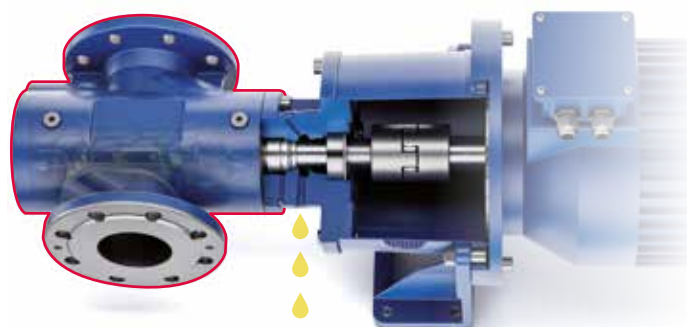

The containment can of the magnetic coupling effectively closes the sealing line between the pipelines.



Disadvantage:

The nominal leakage of the mechanical seal interrupts the sealing line.

Suitable for low sulfur fuels down to 1.1 mm²/s.

 Type.	 Delivery rate.	 Pressure.	 Temperature.	 Applications.
K	0.3 to 174 m ³ /h. 2,900 l/min.	16 bar.	300 °C.	Transfer pump. Circulation pump. Marine burner.
L	0.3 to 12 m ³ /h. 200 l/min.	63 bar.	300 °C.	Transfer pump. Circulation pump. Marine burner.
C	0.3 to 213 m ³ /h. 3,550 l/min.	100 bar.	300 °C.	Transfer pump. Circulation pump. Marine burner.
DKC DLC	0.3 to 16.8 m ³ /h. 280 l/min.	40 bar.	300 °C.	Circulation pump. Marine burner.

KRAL pumps with magnetic coupling in practical use.



Manufacturers of booster modules.

Medium: Heavy Fuel Oil (HFO)
Delivery rate: Up to 660 l/min
Pressure: Up to 16 bar
Temperature: Up to 180 °C
Viscosity: 3 to 760 mm²/s

HFO must be preheated to 130 °C for combustion. Current pumps are therefore specified for 150 °C. Manufacturers of booster modules are now requiring higher temperatures. The reason for this is the higher viscosity HFO made from residual oils, which also may contain abrasive silicates that may damage the mechanical seals. KRAL pumps with magnetic coupling work at temperatures of up to 300 °C without difficulty and are less sensitive to the abrasive materials.

Shipowners.

When the fuel supply fails, ships can be rendered incapable of maneuvering. This situation can threaten the shipowners' image and potentially threaten their very existence. This is the reason why major shipowners have a replacement program. Pumps with mechanical seals are replaced by KRAL pumps with magnetic coupling. KRAL pumps with magnetic coupling are now the standard for any new constructions: Greater reliability and reduced maintenance costs are the result. Shipowners who are particular in demanding high quality and economic efficiency, do not leave the choice of pump to the shipyard. They set the standards themselves.



Ship suppliers.

Screw pumps for the in-board package:

- Transfer pumps.
- Circulation pumps.
- Booster pumps.

KRAL has excellent partnership relationships with the most important ship suppliers. Complete pump programs, price/performance ratios, quality, application know-how and in particular meeting deadlines are important criteria for ship suppliers. If a supplier is late with a delivery, the package supplier must provide preliminary finance for the component suppliers. KRAL customers are always writing to confirm that compared to their rivals, KRAL is astonishingly good at keeping to on time deliveries.

Joint projects.

Our business partners are particularly appreciative of their cooperative collaboration with KRAL. From best possible support to the successful conclusion of the project, friendly business relations are always the order of the day. We take the time to talk to our customers and collaborate closely with them on technical matters. You can rely on KRAL.

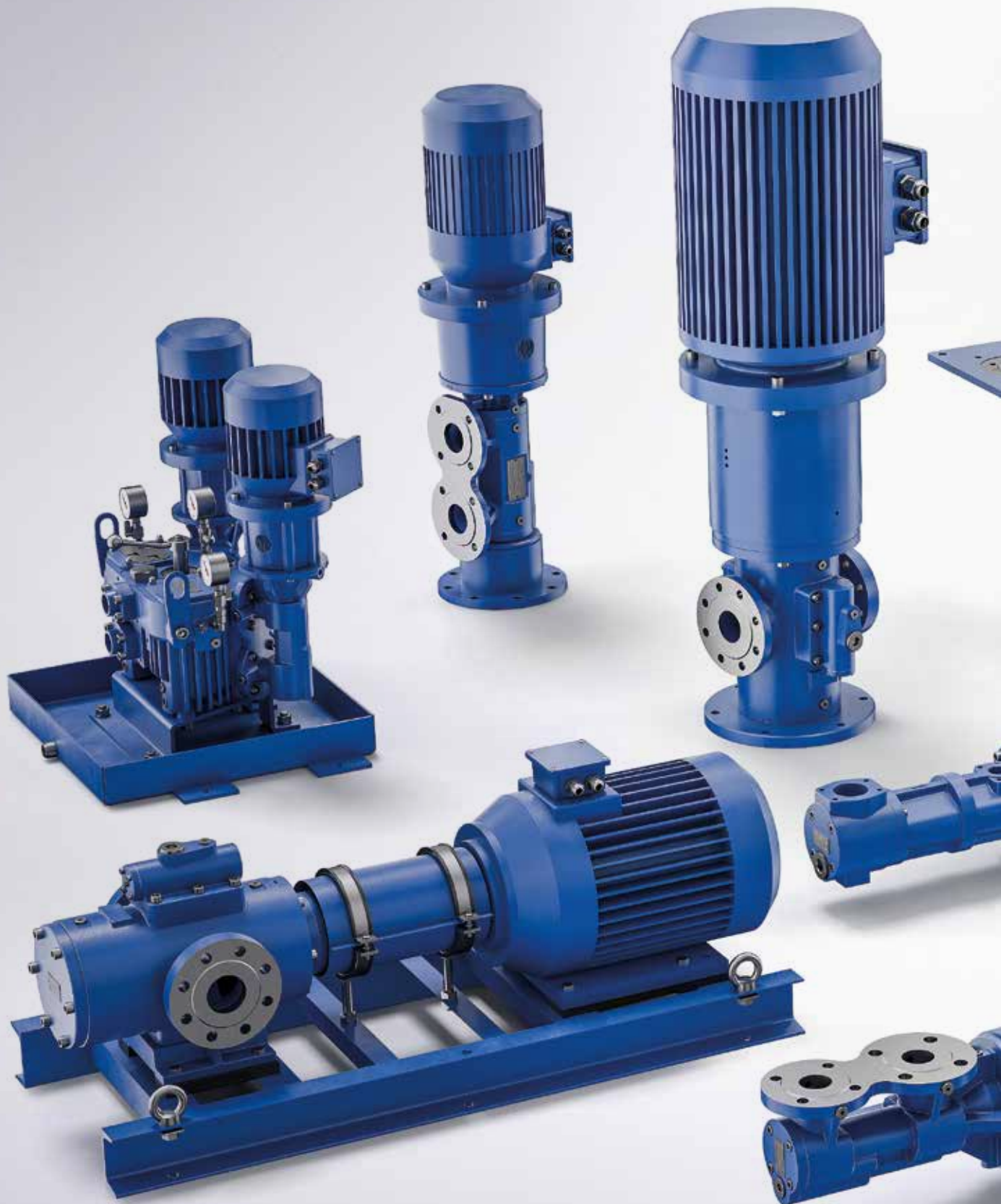

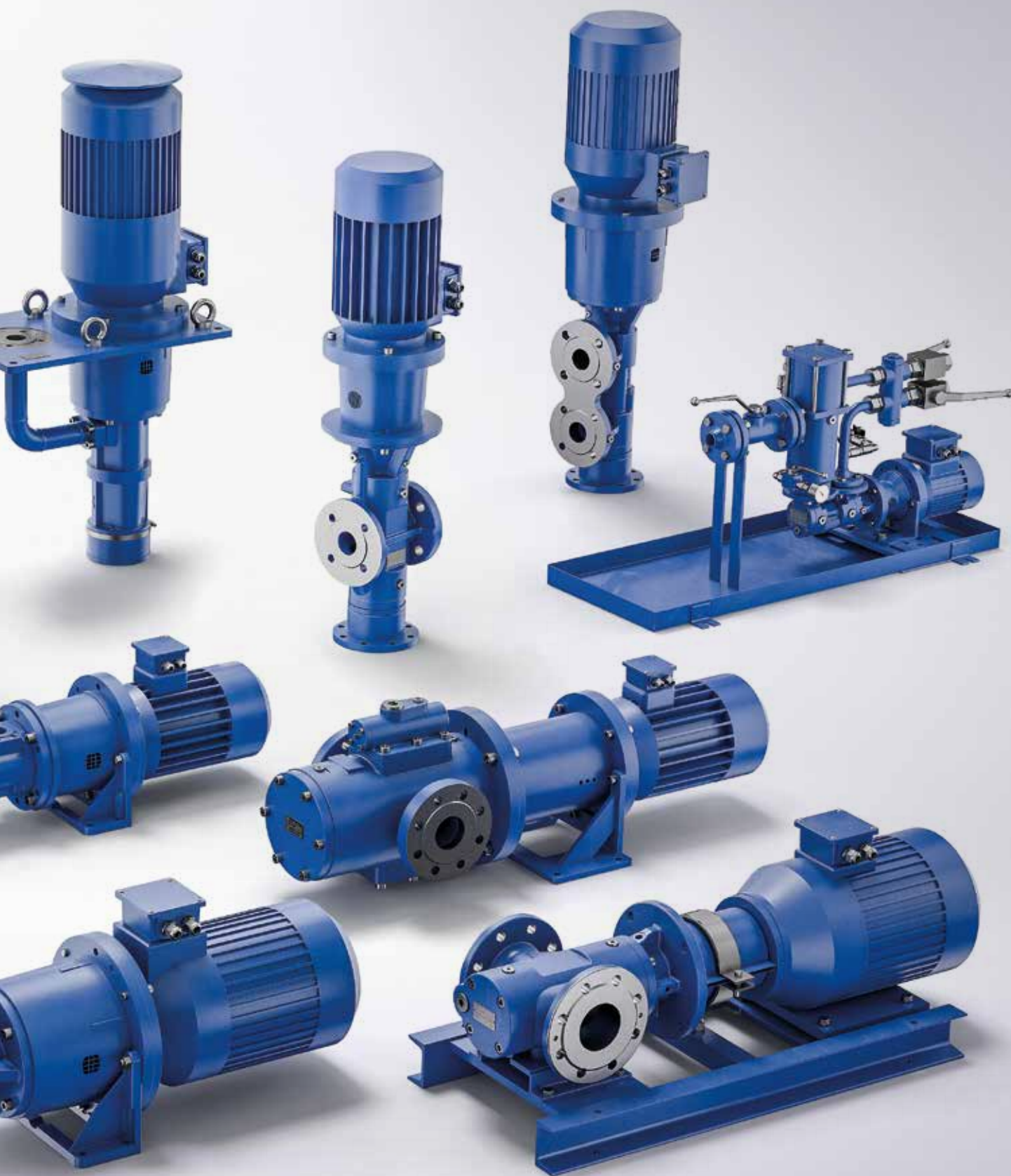



Headquarters.

KRAL GmbH

Bildgasse 40, Industrie Nord
6890 Lustenau, Austria
e-mail: kral@kral.at
Tel.: +43/5577/86644-0

Further locations.

KRAL Deutschland GmbH

88131 Lindau
Germany

KRAL Polska Sp. z o.o.

40-668 Katowice
Poland

KRAL SAS

69100 Villeurbanne
France

KRAL-USA, Inc.

28105 Matthews, NC
USA

KRAL (Wuxi) Machinery Technology Co., Ltd.

214100 Wuxi
China