

Screw pumps ALP Sizes 0100–0280 Magnetic coupling M-type

Operating Instructions



Lit. Code
Manual No.

200007725-1-EN-GB
9062571 02

Component Description

Published by
Alfa Laval SpA
Product Development FCS & Modules
Via Pusiano 2
20900 Monza (MB), Italy

The original instructions are in English

© Alfa Laval Corporate AB 2022-09

This document and its contents are subject to copyrights and other intellectual property rights owned by Alfa Laval Corporate AB. No part of this document may be copied, re-produced or transmitted in any form or by any means, or for any purpose, without Alfa Laval Corporate AB's prior express written permission. Information and services provided in this document are made as a benefit and service to the user, and no representations or warranties are made about the accuracy or suitability of this information and these services for any purpose. All rights are reserved.

Contents

| | | |
|----------|--|-----------|
| 1 | Warning signs in text | 7 |
| 1.1 | Warning signs | 7 |
| 2 | About this document | 9 |
| 2.1 | General information..... | 9 |
| 2.2 | Target groups | 9 |
| 2.3 | Symbols..... | 9 |
| 2.4 | Associated documents..... | 9 |
| 3 | Safety | 11 |
| 3.1 | Proper use | 11 |
| 3.2 | Safety information..... | 12 |
| 3.3 | Safety instructions for magnetic coupling systems..... | 13 |
| 4 | Labelling | 15 |
| 4.1 | Type code | 15 |
| 4.2 | Communication plate | 16 |
| 5 | Technical data | 17 |
| 5.1 | Operating limits | 17 |
| 5.2 | Required NPSH values | 18 |
| 5.3 | Weights..... | 19 |
| 5.4 | Dimensions..... | 20 |
| 5.5 | Capacity tables | 22 |
| 5.6 | Noise levels | 23 |
| 5.7 | Overflow valve | 23 |
| 5.8 | Materials | 23 |
| 6 | Function description | 25 |
| 6.1 | Structure..... | 25 |
| 6.1.1 | Standard direction of rotation..... | 26 |
| 6.1.2 | Flow direction | 26 |
| 6.2 | Magnetic coupling | 26 |
| 6.3 | Overflow valve | 26 |
| 7 | Transportation, Storage and Disposal | 27 |
| 7.1 | Unpacking and checking the state of delivery | 27 |
| 7.2 | Lifting the pump/pump unit | 27 |
| 7.3 | Storage | 28 |
| 7.4 | Preservation | 29 |
| 7.4.1 | Removing the preservation | 30 |

| | | |
|-----------|---|-----------|
| 7.4.2 | Disposing of the pump | 31 |
| 8 | Installation, removal and connection..... | 33 |
| 8.1 | Safety instruction on installation, removal and connection..... | 33 |
| 8.2 | Installation | 33 |
| 8.3 | Installing the pump | 34 |
| 8.4 | Protect the pump against soiling | 35 |
| 8.4.1 | Connecting the pump to the pipe system..... | 35 |
| 8.4.2 | Connecting the motor | 36 |
| 8.5 | Removing the pump | 37 |
| 9 | Operation..... | 39 |
| 9.1 | Commissioning..... | 39 |
| 9.2 | Cleaning the pipe system | 40 |
| 9.3 | Filling the pump..... | 41 |
| 9.4 | Filling the pump via the suction or pressure connection..... | 42 |
| 9.5 | Checking direction of rotation | 43 |
| 9.6 | Commissioning the pump | 44 |
| 9.7 | Taking pump out of operation | 45 |
| 9.8 | Recommissioning the pump..... | 46 |
| 10 | Maintenance..... | 47 |
| 10.1 | Safety instructions on maintenance and repairs | 47 |
| 10.2 | Required maintenance | 48 |
| 10.3 | Magnetic coupling | 48 |
| 10.4 | Ball bearing..... | 48 |
| 10.5 | Replacing the magnetic coupling | 49 |
| 10.5.1 | Dismantling the outer rotor | 49 |
| 10.5.2 | Dismantling the inner rotor..... | 52 |
| 10.6 | Installing the magnetic coupling..... | 54 |
| 10.6.1 | Mounting the inner rotor..... | 54 |
| 10.6.2 | Mounting the outer rotor | 58 |
| 10.7 | Replacing the ball bearing | 60 |
| 10.7.1 | Removing the ball bearing | 60 |
| 10.7.2 | Installing the ball bearing | 62 |
| 11 | Troubleshooting | 63 |
| 11.1 | Possible faults | 63 |
| 11.2 | Troubleshooting..... | 64 |
| 12 | Spare Parts..... | 67 |
| 12.1 | ALP magnetic coupling spare parts..... | 67 |
| 12.2 | ALP Magnetic coupling - Maintenance kit..... | 68 |

| | | |
|-----------|---|-----------|
| 12.2.1 | ALP 0100-0115 Magnetic coupling - Maintenance kit..... | 68 |
| 12.2.2 | ALP 0165-0280 Magnetic coupling - Maintenance kit | 69 |
| 12.3 | Tensioning element..... | 70 |
| 12.4 | Valve body (cone)..... | 70 |
| 12.5 | Cylindrical spring..... | 70 |
| 12.6 | Containment can..... | 70 |
| 12.7 | Screw plug for ALP magnetic coupling..... | 71 |
| 13 | Appendix | 73 |
| 13.1 | General drawings | 73 |
| 13.2 | Parts table | 74 |
| 13.3 | Tightening torques | 75 |
| 13.4 | Required tool for maintenance work..... | 76 |
| 14 | EC Declaration of conformity | 77 |

1 Warning signs in text

1.1 Warning signs

Pay attention to the safety instructions in this manual. Below are definitions of the three grades of warning signs used in the text where there is a risk for injury to personnel.

**DANGER DANGER**

Indicates an imminently hazardous situation which, if not avoided, will result in death or serious injury.

**WARNING WARNING**

Indicates a potentially hazardous situation which, if not avoided, could result in death or serious injury.

**CAUTION CAUTION**

Indicates a potentially hazardous situation which, if not avoided, may result in minor or moderate injury.

**NOTE NOTE**

Indicates a potentially hazardous situation which, if not avoided, may result in property damage.



Safety



Safety

2 About this document





2.1 General information

The operating instructions form part of the pump or of the pump unit and must be kept for future reference. Further more please observe the associated documents.

2.2 Target groups

| Target group | Tasks |
|-------------------------------|---|
| Operator-owner | <ul style="list-style-type: none"> • Keep these instructions available at the system site for future reference. • Ensure that employees read and observe these instructions and the associated documents, in particular the safety instructions and warnings. • Observe additional system-specific directives and regulations. |
| Specialist personnel, fitters | <ul style="list-style-type: none"> • Read, observe and follow these instructions and the associated documents, in particular the safety instructions and warnings. |

2.3 Symbols

| Symbol | Meaning |
|---|--|
|  | Procedures mechanical installation. |
|  | Procedures electrical installation. |
|  | Check or fault table. |
|  | Safety instructions for persons with pacemakers. |
|  | Request for action. |

2.4 Associated documents

- Pump operating instructions.
- ATEX supplementary instructions for operation in potentially explosive areas.
- Declaration of conformity according to EU Directive 2006/42/EC.
- Declaration of conformity according to EU Directive 94/9/EC.
- Manufacturer's declaration as per EU Directive 97/23/EC.
- Technical documentation for supplied components.

3 Safety

3.1 Proper use

- Use the pump solely for transporting lubricating liquids that are chemically neutral and that contain no gas or solid components.
- Use the pump only within the performance limitations specified on the rating plate and in the "Technical data" section. In the case of operating data that does not agree with the specifications on the rating plate, please contact the manufacturer.
- The pump is specifically configured for the operating pressure stated by the customer. In the case of a significant difference between actual and configured operating pressure damages can occur even within the stated performance limitations. This applies both to notably higher as well as to notably lower operating pressures. In case of any doubt, please contact the manufacturer.



Safety

3.2 Safety information

NOTE

The following general safety instructions must be observed.

- No liability is accepted for damage arising through non-observance of the operating instructions.
 - Read the operating instructions carefully and observe them.
 - The operator-owner is responsible for the observance of the operating instructions.
 - Installation, removal and installation work may only be carried out by specialist personnel.
- In order for the warranty to remain valid, corrective maintenance carried out during the warranty period requires the express permission of the manufacturer.
- Observe the general regulations for the prevention of accidents as well as the local safety and operating instructions.
- Observe the valid national and international standards and specifications of the installation location.
- In case of systems with an increased potential of danger to humans and/or machines the failure of a pump may not lead to injuries or damage to property.
 - Always equip systems with an increased potential of danger with alarm equipment.
 - Maintain and check the protective/alarm equipment regularly.
- The pumped liquids can be dangerous (e.g. hot, dangerous to health, poisonous, combustible). Observe the safety regulations for handling dangerous materials.
- Pumped liquid can be subject to high pressure and can cause damage and/or personal injury should leaks occur.



Safety

3.3 Safety instructions for magnetic coupling systems.

Magnetic fields from magnetic coupling systems (MCS) can influence the function and operational safety of electrical and electronic devices.

**NOTE**

The following safety instructions must be observed.

Additional safety instructions for magnetic coupling systems.



- Keep the MCS away from pacemakers. There is a danger to life!
 - Under no circumstances may persons with pacemakers perform installation, dismantling or maintenance work.
- Persons with pacemakers must comply with the following safe distances to the MCS:
 - 3 m distance to the openly accessible MCS.
 - 1 m distance to pump units with installed MCS.
- Do not bring the MCS in the immediate area of PCs, data carriers and other electronic components.
- Keep the MCS away from clocks, magnetized tools and measuring equipment as well as all magnetizable parts.
- Do not bring both the MCS parts together, as this can destroy the magnetic coupling system.

Safety



Safety

4 Labelling

4.1 Type code

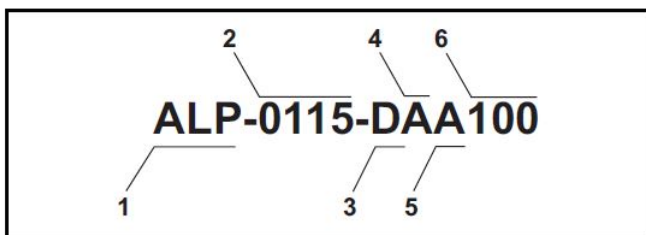

1. Model
2. Size
3. Seal type
4. Overflow valve
5. Completion
6. Motor size

Figure 1: Type code

Table 1: Type code description

| Pos. | Designation | Type | |
|------|----------------|--|--|
| 1 | Model | ALP | Single pump. |
| 2 | Size | Corresponds to flow rate in [l/min] at 1 450 min ⁻¹ | |
| 3 | Shaft seal | B | Mechanical seal of hard material. |
| | | D | Magnetic coupling. Up to April 2022. |
| | | M | Magnetic coupling. From May 2022. |
| 4 | Overflow valve | | Opening at differential pressure [bar]. |
| | | A | 6 ± 10 % |
| | | B | 10 ± 10 % |
| 5 | Completion | A | Pump with free shaft end. |
| | | B | Pump unit for vertical mounting, with pump bracket and coupling. |
| | | C | Pump unit for horizontal mounting, with pump bracket, pump bracket foot and coupling. |
| | | D | Pump unit for vertical mounting, with pump bracket, coupling and motor. |
| | | E | Pump unit for horizontal mounting, with pump bracket, pump bracket foot, coupling and motor. |
| 6 | Motor size | 90 | |
| | | 100 | |
| | | 112 | |
| | | 132 | |
| | | 160 | |
| | | 180 | |

4.2 Communication plate

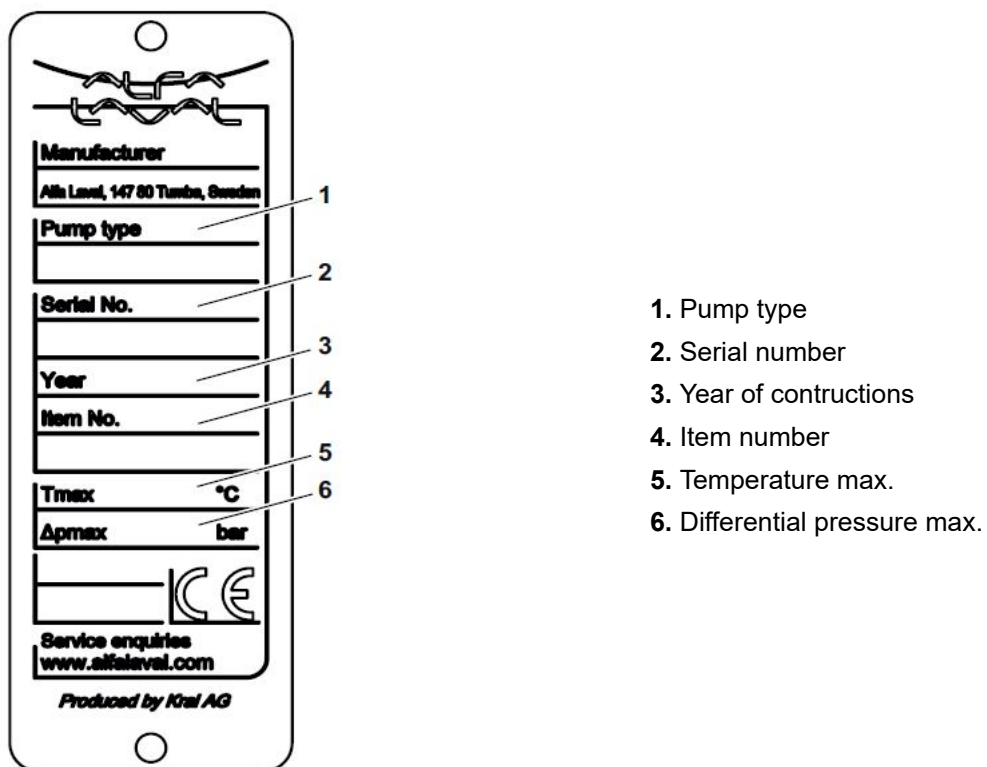

Figure 2: Rating plate

5 Technical data

5.1 Operating limits

Table 2: Operating limits

| | Size 100 - 280 | |
|--|------------------|------------------|
| | Overflow valve A | Overflow valve B |
| Differential pressure max. [bar] | 5.4 | 9 |
| End pressure max. [bar] | 16 | 16 |
| Valve opening pressure [bar] | 6 ± 10 % | 10 ± 10 % |
| Temperature max. [°C] | 155 | 155 |
| Temperature min. [°C] for pump materials | -20 | -20 |
| Viscosity min. - max. [mm ² /s] | 1.4 - 10000 | 1.4 - 10000 |
| Rotation speed [min ⁻¹] | | |
| @ 50 Hz | 2900 | 2900 |
| @ 60 Hz | 3500 | 3500 |

5.2 Required NPSH values

The following table lists the required NPSH values during operation with a low-volatile liquid such as lubricating oil or hydraulic liquid. When liquids have a readily volatile component content, the required NPSH values increase notably:

- When the pumped liquid contains water (e. g. heavy fuel oil), the values in the table have to be increased by the vapor pressure of the water at the specified operating temperature.

The required NPSH values also need to be increased if there are gas contents, regardless of whether it is dissolved or not. In case of any doubt, please contact the manufacturer.

Table 3: Required NPSH values

| Size | Viscosity [mm ² /s] | NPSH value [mWC] @ Rotation speed [min ⁻¹] | | | | Size | Viscosity [mm ² /s] | NPSH value [mWC] @ Rotation speed [min ⁻¹] | | | |
|---------|-----------------------------------|---|------|------|------|---------|-----------------------------------|---|------|------|------|
| | | 1450 | 1750 | 2900 | 3500 | | | 1450 | 1750 | 2900 | 3500 |
| ALP 100 | 6 | 2.0 | 2.0 | 2.8 | 3.4 | ALP 215 | 6 | 2.2 | 2.4 | 4.0 | 5.2 |
| | 37 | 2.0 | 2.2 | 3.2 | 3.8 | | 37 | 2.4 | 2.7 | 4.5 | 6.0 |
| | 152 | 2.4 | 2.6 | 3.8 | 4.6 | | 152 | 2.8 | 3.2 | 5.5 | 7.5 |
| | 380 | 2.9 | 3.1 | 4.6 | 5.7 | | 380 | 3.4 | 3.9 | 6.9 | 9.5 |
| ALP 115 | 6 | 2.0 | 2.1 | 2.7 | 3.2 | ALP 230 | 6 | 2.1 | 2.4 | 4.0 | 5.3 |
| | 37 | 2.0 | 2.2 | 3.0 | 3.6 | | 37 | 2.4 | 2.7 | 4.5 | 6.0 |
| | 152 | 2.4 | 2.5 | 3.6 | 4.4 | | 152 | 2.8 | 3.2 | 5.5 | 7.5 |
| | 380 | 2.8 | 3.0 | 4.4 | 5.4 | | 380 | 3.4 | 3.9 | 6.9 | 9.5 |
| ALP 165 | 6 | 2.0 | 2.1 | 2.9 | 3.6 | ALP 280 | 6 | 2.3 | 2.6 | 4.5 | 6.1 |
| | 37 | 2.1 | 2.3 | 3.3 | 4.1 | | 37 | 2.5 | 2.9 | 5.1 | 7.0 |
| | 152 | 2.5 | 2.7 | 4.0 | 5.0 | | 152 | 3.0 | 3.5 | 6.3 | 8.8 |
| | 380 | 2.9 | 3.2 | 4.9 | 6.1 | | 380 | 3.6 | 4.2 | 8.0 | 11.4 |

5.3 Weights

Table 4: ALP weights, with magnetic coupling

| Pump size | Motor size | Coupling | Pump bracket foot | Weights (kg) | | | Note |
|-----------|------------|----------|-------------------|--------------|---------|--------------|------|
| | | | | Pump | Bracket | Total weight | |
| ALP-0100 | 132 | 30 Nm | no | 23.0 | 6.7 | 29.7 | |
| | | | yes | | 7.8 | 30.8 | |
| ALP-0115 | 132 | 30 Nm | no | 23.0 | 6.7 | 29.7 | |
| | | | yes | | 7.8 | 30.8 | |
| ALP-0165 | 132 | 60 Nm | no | 38.3 | 9.1 | 47.4 | |
| | | | yes | | 10.2 | 48.5 | |
| | 160 | 60 Nm | no | 38.3 | 11.6 | 49.9 | |
| | | | yes | | 14.0 | 52.3 | |
| ALP-215 | 160 | 60 Nm | no | 38.3 | 11.6 | 49.9 | |
| | | | yes | | 14.0 | 52.3 | |
| ALP-0230 | 160 | 60 Nm | no | 42.4 | 11.6 | 54.0 | |
| | | | yes | | 14.0 | 56.4 | |
| ALP-0280 | 160 | 60 Nm | no | 42.4 | 11.6 | 54.0 | |
| | | | yes | | 14.0 | 56.4 | |

5.4 Dimensions

Table 5: Dimensions ALP pump

| Size | Pump [mm] | | | | | | | | | | | | Shaft end [mm] | | | |
|---------|-----------|----|-------|-------|-----|-----|-----|----|----|-------|----|----|----------------|----|---|---|
| | L1 | L2 | L3 | L4 | D1 | D2 | D3 | S1 | Z1 | g1/g2 | B1 | B2 | d | l | t | u |
| 100-115 | 59 | 14 | 129 | 272.5 | 160 | 138 | 75 | 11 | 4 | 110 | 20 | 20 | 19 | 43 | - | - |
| 165-215 | 57 | 17 | 140 | 333.5 | 230 | 200 | 110 | 14 | 4 | 122.5 | 20 | 20 | 28 | 47 | - | - |
| 230-280 | 63.5 | 18 | 178.5 | 363.5 | 230 | 200 | 110 | 14 | 4 | 140 | 20 | 20 | 28 | 47 | - | - |

Table 6: Dimension pump unit with magnetic coupling

| Size | Motor size | Magnet power [Nm] | Pump unit [mm] | | | | | | | | | | | | | |
|---------|------------|-------------------|----------------|-----|-----|------|-----|-----|----|----|-------|----|-----|-----|-----|-----|
| | | | LP | LL | LM* | LG** | L5 | L6 | L7 | L8 | L9 | H1 | H2 | B3 | B4 | S4 |
| 100-115 | 90 | 75/20 | 272.5 | 140 | * | ** | 60 | 90 | 19 | 15 | 190 | 12 | 112 | 210 | 180 | Ø11 |
| | 100/112 | 75/30 | 272.5 | 148 | * | ** | 60 | 97 | 39 | 21 | 178 | 15 | 132 | 250 | 220 | Ø13 |
| | 132 | 75/40 | 272.5 | 196 | * | ** | 80 | 116 | 40 | 20 | 205 | 18 | 160 | 290 | 260 | Ø13 |
| 165-215 | 100/112 | 75/40 | 333.5 | 175 | * | ** | 60 | 97 | 39 | 21 | 216 | 15 | 132 | 250 | 220 | Ø13 |
| | 132 | 75/60 | 333.5 | 210 | * | ** | 80 | 116 | 40 | 20 | 230 | 18 | 160 | 290 | 260 | Ø13 |
| | 160 | 75/60 | 333.5 | 256 | * | ** | 110 | 150 | 45 | 20 | 241 | 22 | 180 | 340 | 300 | Ø18 |
| 230-280 | 132 | 75/60 | 363.5 | 210 | * | ** | 80 | 116 | 40 | 20 | 268.5 | 18 | 160 | 290 | 260 | Ø13 |
| 230 | 160 | 75/60 | 363.5 | 256 | * | ** | 110 | 150 | 45 | 20 | 279.5 | 22 | 180 | 340 | 300 | Ø18 |
| 280 | 160 | 110/100 | 363.5 | 228 | * | ** | 110 | 150 | 45 | 20 | 251.5 | 22 | 180 | 340 | 300 | Ø18 |
| 230-280 | 180 | 110/100 | 363.5 | 228 | * | ** | 110 | 150 | 45 | 20 | 251.5 | 22 | 180 | 340 | 300 | Ø18 |

* Depends on motor model.

** LG=LP+LL+LM

Dimensional drawings of ALP pump and pump unit

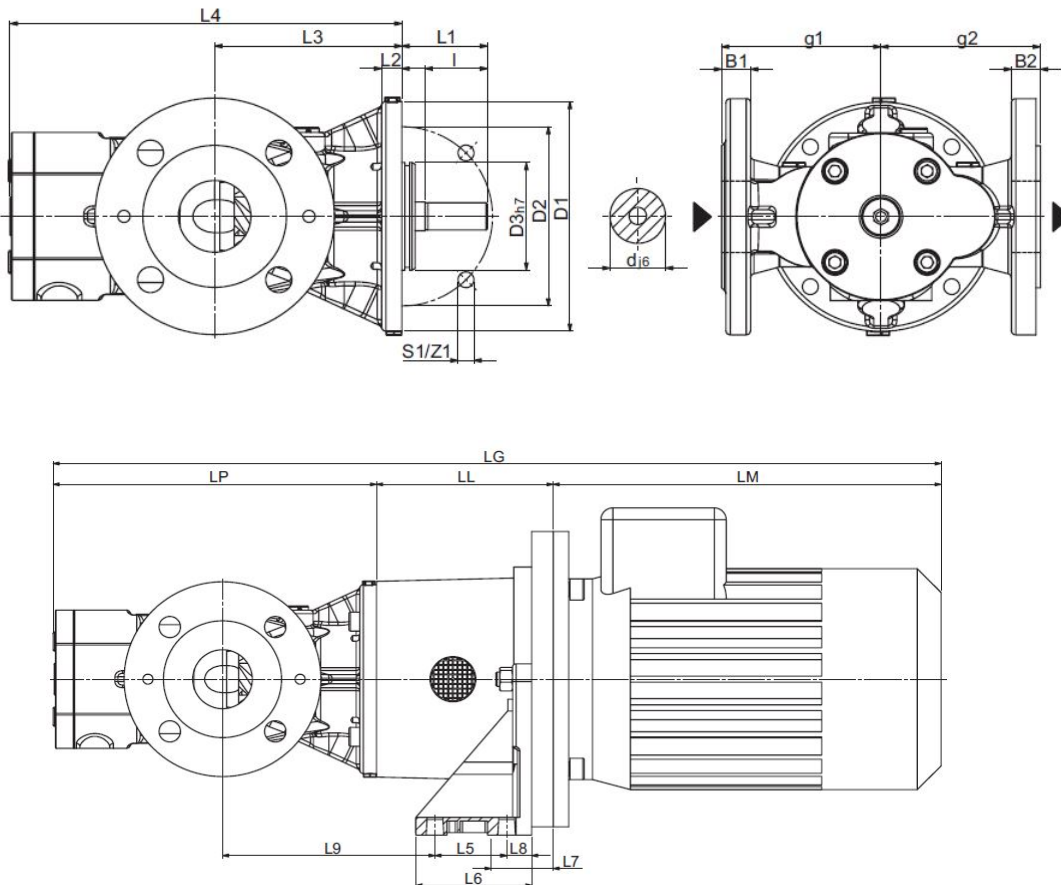

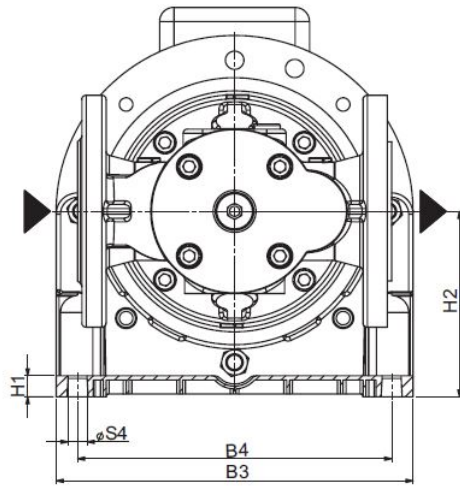

5.5 Capacity tables

Table 7: Capacity at 50 Hz, $\Delta p = 4$ bar

| Size | Rotation speed | v_{max}^* | Motor | Delivery rate [l/min] at viscosity [mm ² /s] | | | | | | | | | |
|--------|----------------------|----------------------|-------|---|-------|-------|-------|-------|-------|-------|-------|-------|--------|
| | [min ⁻¹] | [mm ² /s] | [kW] | 13 | 30 | 40 | 60 | 100 | 180 | 380 | 460** | 700** | 1200** |
| ALP100 | 2800 | 370 | 5.5 | 174.5 | 178.7 | 180.0 | 181.5 | 183.0 | 184.3 | 185.5 | 185.7 | 186.2 | 186.6 |
| | 1400 | 1600 | 3.0 | 80.5 | 84.7 | 85.9 | 87.4 | 88.9 | 90.2 | 91.4 | 91.6 | 92.1 | 92.6 |
| | 900 | 2450 | 1.8 | 46.9 | 51.1 | 52.3 | 53.8 | 55.3 | 56.6 | 57.8 | 58.1 | 58.5 | 59.0 |
| ALP115 | 2800 | 170 | 5.5 | 210.9 | 214.5 | 215.6 | 216.9 | 218.3 | 219.4 | 220.4 | 220.7 | 221.0 | 221.4 |
| | 1400 | 1270 | 3.0 | 99.5 | 103.2 | 104.3 | 105.6 | 106.9 | 108.0 | 109.1 | 109.3 | 109.7 | 110.1 |
| | 900 | 2150 | 1.8 | 59.7 | 63.4 | 64.5 | 65.8 | 67.1 | 68.2 | 69.3 | 69.5 | 69.9 | 70.3 |
| ALP165 | 2800 | 240 | 7.5 | 294.5 | 299.4 | 300.9 | 302.7 | 304.5 | 306.0 | 307.4 | 307.7 | 308.3 | 308.8 |
| | 1400 | 1400 | 4.0 | 139.2 | 144.1 | 145.6 | 147.4 | 149.2 | 150.7 | 152.2 | 152.4 | 153.0 | 153.5 |
| | 900 | 2280 | 2.6 | 83.7 | 88.7 | 90.2 | 91.9 | 93.7 | 95.3 | 96.7 | 97.0 | 97.5 | 98.1 |
| ALP215 | 2800 | 30 | 7.5 | 338.4 | 394.0 | 395.7 | 397.7 | 399.7 | 401.5 | 403.1 | 403.4 | 404.1 | 404.7 |
| | 1400 | 880 | 4.0 | 185.0 | 190.7 | 192.4 | 194.4 | 196.4 | 198.2 | 199.8 | 200.1 | 200.7 | 201.3 |
| | 900 | 1750 | 2.6 | 112.4 | 118.0 | 119.7 | 121.8 | 123.8 | 125.5 | 127.2 | 127.5 | 128.1 | 128.7 |
| ALP230 | 2800 | 85 | 11.0 | 421.5 | 427.2 | 428.9 | 430.9 | 433.0 | 434.8 | 436.4 | 436.7 | 437.3 | 438.0 |
| | 1400 | 1070 | 5.5 | 201.5 | 207.2 | 208.9 | 210.9 | 213.0 | 214.8 | 216.4 | 216.7 | 217.3 | 218.0 |
| | 900 | 1950 | 2.6 | 118.8 | 125.7 | 127.8 | 130.3 | 132.8 | 135.0 | 137.0 | 137.4 | 138.2 | 138.9 |
| ALP280 | 2800 | 4 | 7.5 | 505.8 | 512.6 | 514.7 | 517.1 | 519.6 | 521.7 | 522.7 | 524.1 | 524.8 | 525.6 |
| | 1400 | 730 | 5.5 | 241.8 | 248.6 | 253.1 | 250.7 | 255.6 | 257.7 | 259.7 | 260.1 | 260.8 | 261.6 |
| | 900 | 1580 | 3.6 | 147.5 | 154.3 | 156.4 | 158.8 | 161.3 | 163.4 | 165.4 | 165.8 | 166.5 | 167.3 |

Table 8: Capacity at 60 Hz, $\Delta p = 4$ bar

| Size | Rotation speed | v_{max}^* | Motor | Delivery rate [l/min] at viscosity [mm ² /s] | | | | | | | | | |
|---------|----------------------|----------------------|-------|---|-------|-------|-------|-------|-------|-------|-------|-------|--------|
| | [min ⁻¹] | [mm ² /s] | [kW] | 13 | 30 | 40 | 60 | 100 | 180 | 380 | 460** | 700** | 1200** |
| ALP 100 | 3400 | 150 | 6.6 | 214.8 | 219.0 | 220.3 | 221.8 | 223.3 | 224.6 | 225.8 | 226.0 | 226.5 | 226.9 |
| | 1700 | 1220 | 3.6 | 100.6 | 104.8 | 106.1 | 107.6 | 109.1 | 110.4 | 111.6 | 111.8 | 112.3 | 112.7 |
| | 1100 | 2080 | 2.6 | 60.3 | 64.5 | 65.8 | 67.3 | 68.8 | 70.1 | 71.3 | 71.5 | 72.0 | 72.4 |
| ALP 115 | 3400 | 33 | 4.8 | 258.6 | 262.3 | 263.4 | 264.7 | 266.0 | 267.1 | 268.2 | 268.4 | 268.8 | 269.2 |
| | 1700 | 900 | 3.6 | 123.4 | 127.0 | 128.1 | 129.4 | 130.7 | 131.9 | 132.9 | 133.1 | 133.5 | 133.9 |
| | 1100 | 1750 | 2.6 | 75.7 | 79.3 | 80.4 | 81.7 | 83.0 | 84.2 | 85.2 | 85.4 | 85.8 | 86.2 |
| ALP 165 | 3400 | 70 | 9.0 | 361.0 | 366.0 | 367.5 | 369.2 | 371.0 | 372.6 | 374.0 | 374.3 | 374.8 | 375.3 |
| | 1700 | 1030 | 4.8 | 172.5 | 177.4 | 178.9 | 180.7 | 182.5 | 184.0 | 185.4 | 185.7 | 186.2 | 186.8 |
| | 1100 | 1900 | 3.6 | 105.9 | 110.9 | 112.4 | 114.1 | 115.9 | 117.5 | 118.9 | 119.2 | 119.7 | 120.2 |
| ALP 215 | 3400 | - | #9.0# | 475.5 | 481.2 | 482.9 | 484.9 | 486.9 | 488.7 | 490.3 | 490.6 | 491.2 | 491.8 |
| | 1700 | 550 | 4.8 | 228.6 | 234.2 | 235.9 | 238.0 | 240.0 | 241.7 | 243.4 | 243.7 | 244.3 | 244.9 |
| | 1100 | 1350 | 3.6 | 141.4 | 147.1 | 148.8 | 150.8 | 152.8 | 154.6 | 156.2 | 156.5 | 157.1 | 157.8 |
| ALP 230 | 3400 | 150 | 6.6 | 214.8 | 219.0 | 220.3 | 221.8 | 223.3 | 224.6 | 225.8 | 226.0 | 226.5 | 226.9 |
| | 1700 | 1220 | 3.6 | 100.6 | 104.8 | 106.1 | 107.6 | 109.1 | 110.4 | 111.6 | 111.8 | 112.3 | 112.7 |
| | 1100 | 2080 | 2.6 | 60.3 | 64.5 | 65.8 | 67.3 | 68.8 | 70.1 | 71.3 | 71.5 | 72.0 | 72.4 |
| ALP 280 | 3400 | 2 | 9.0 | 515.8 | 521.5 | 523.2 | 525.2 | 527.3 | 529.0 | 530.7 | 531.0 | 531.6 | 532.3 |
| | 1700 | 720 | 6.6 | 248.6 | 254.3 | 256.0 | 258.1 | 260.1 | 261.9 | 263.5 | 263.9 | 264.5 | 265.1 |
| | 1100 | 1550 | 3.6 | 154.3 | 160.0 | 161.8 | 163.8 | 165.8 | 167.6 | 169.3 | 169.6 | 170.2 | 170.8 |

* Max. possible viscosity without cavitation with a suction head of -4 mWC @ sea level.

** Re-sizing of motor required.

5.6 Noise levels

Guide values at 1 m distance, 1 450 min⁻¹, 8 bar.

Table 9: Noise levels

| Sound pressure level max. ± 3 [dB(A)] | | | |
|---------------------------------------|-----------|-----------|-----------|
| Size | 100 - 115 | 165 - 215 | 230 - 280 |
| Pump | 65 | 70 | 71 |

5.7 Overflow valve

Table 10: Short-circuit pressure of the overflow valve

| Size | Short-circuit pressure [bar] at rotation speed [min ⁻¹] | | | | | | | |
|-----------|---|------|------|------|------------------|------|------|------|
| | Overflow valve A | | | | Overflow valve B | | | |
| | 1450 | 1750 | 2900 | 3500 | 1450 | 1750 | 2900 | 3500 |
| 100 - 115 | 7.5 | 8.0 | 9.0 | 10.0 | 12.0 | 12.5 | 13.0 | 14.0 |
| 165 - 215 | 8.0 | 8.5 | 10.0 | 11.0 | 13.0 | 13.5 | 15.0 | 16.0 |
| 230 - 280 | 9.0 | 9.5 | 11.0 | 12.0 | 14.0 | 14.5 | 16.0 | 17.0 |

5.8 Materials

Table 11: Materials

| | Material name | Material no. |
|--------------|---------------|--------------|
| Pump housing | EN-GJS-400-15 | EN-JS1030 |
| End cover | 16MnCr5 | 1.7139 |
| Screw set | 35S20 | 1.0726 |

6 Function description

6.1 Structure

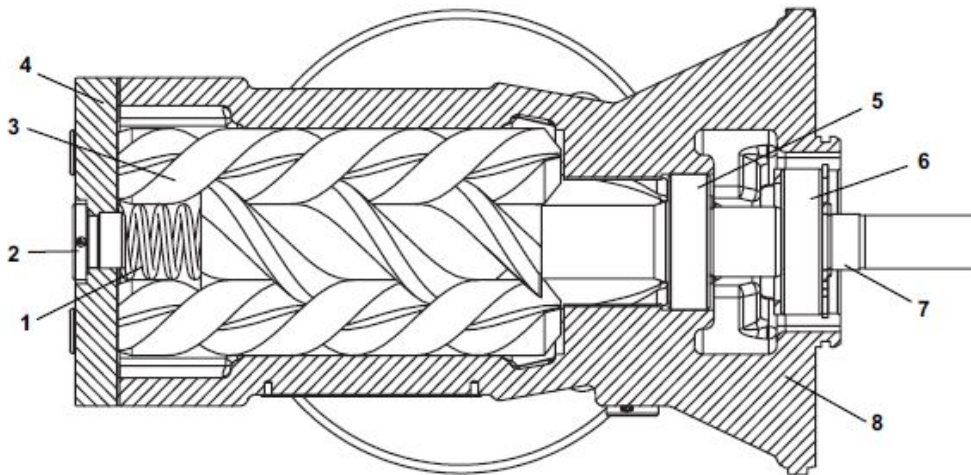

Figure 3: Structure of ALP pump

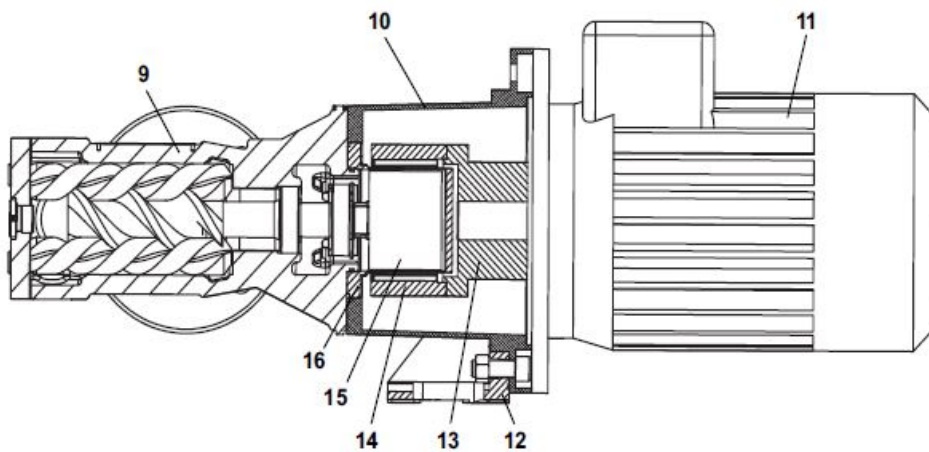

Figure 4: Structure of ALP pump with magnetic coupling and motor

- | | | | |
|-------------------|-----------------------|-----------------------|---------------------|
| 1. Overflow valve | 5. Balancing cylinder | 9. Pump | 13. Coupling hub |
| 2. Screw plug | 6. Ball bearing | 10. Pump bracket | 14. Outer rotor |
| 3. Idle screw | 7. Main screw | 11. Motor | 15. Inner rotor |
| 4. End cover | 8. Pump housing | 12. Pump bracket foot | 16. Containment can |

Screw pumps are rotating displacement pumps whose displacement effect results from the meshing of three rotating screws and the enclosing housing. The radial support of the screws is effected by the sliding contact in the housing which requires lubrication by the pumped liquid. Screw pumps are therefore not suitable for dry running and can only be used up to specific pressure and viscosity limits. Due to the narrow tolerances, pumping of suspended solids is not possible.

Axial support of the main screw is carried out by a deep-groove ball bearing. An internal overflow valve protects against excessive pressure that could cause housing parts to burst.

6.1.1 Standard direction of rotation

Clockwise, as seen from the drive; marked on the housing by two arrows.

Refer to .

6.1.2 Flow direction

Marked on the housing by two arrows.

Refer to .

6.2 Magnetic coupling

The shaft end of the pump is enclosed by a containment can, that is connected air-tight with the motor-side flange of the pump. Special rotors equipped with powerful magnets are used to transfer the torque from the motor to the pump. The inner rotor is fixed at the shaft end and driven from the outer rotor, which in turn is fixed to the shaft of the motor. The torque is thus transferred contact-free by means of magnetic field between the outer and inner rotor.

The pressure discharge of the containment can approximately corresponds to the pressure on the suction side of the pump.

6.3 Overflow valve

The integrated overflow valve prevents very high pressures which can result in housing parts bursting. The valve is purely there as a safety element and should not be used for control or regulation such as maintaining pressure. Circulation through the overflow valve for too long heats the pump to excess. This reduces viscosity and can ultimately lead to pump failure. Two variants of the overflow valve are available.

The valve spring is pretensions to the respective opening pressure.

Table 12: Pretension of the valve spring

| | Overflow valve A | Overflow valve B |
|-----------------------------|------------------|------------------|
| Pretension Δp [bar] | $6 \pm 10 \%$ | $10 \pm 10 \%$ |

Short-circuit pressure of the overflow valve: Refer to [Overflow valve](#) on page 23.

7 Transportation, Storage and Disposal

7.1 Unpacking and checking the state of delivery



1. Upon delivery unpack the pump/pump unit and check for transport damage.
2. Report any transport damage immediately to the manufacturer.
3. Dispose of packing materials in accordance with the locally applicable regulations.

7.2 Lifting the pump/pump unit

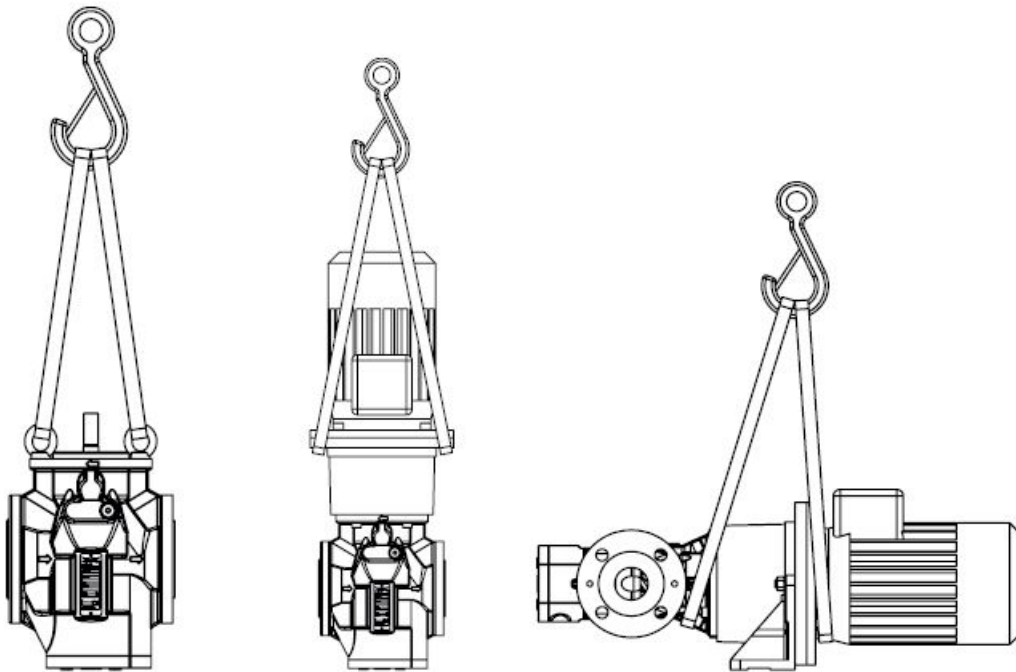

Figure 5: Attachment of hoisting equipment - schematic diagrams



Risk of injury and/or damage to equipment should the pump/pump unit fall.

- Use intact and correctly dimensioned hoisting equipment suitable for the weight to be lifted.
- Choose the attachment points of the hoisting equipment according to the centre of gravity and weight distribution.
- Always use at least two slings.
- For vertical transport: secure motor additionally against tilting.
- Do not stand under raised loads.



Attach the hoisting equipment to the pump unit, and lift the pump unit.

7.3 Storage

During the test run, the internal components of the pump are wetted with test oil, which has a preservative effect. The pipe connections are fitted with protective covers. The external components of the pump are preserved with a single-coat PU based two-component paint. The preservative applied at the factory will protect the pump for about six weeks, if it is stored in a dry and clean location. The manufacturer offers a long-term preservation for storage times of up to 60 months. With long term conservation the pump is additionally packed in hermetically sealing anti-corrosion paper.

7.4 Preservation

Preservation has to be carried out in the following cases:

- **For standard delivery** : for storage periods exceeding six weeks and in case of adverse storage conditions such as high humidity, salty air, etc.
- **For delivery with long-term preservation**: If the packaging has been opened or damaged.

Preserving the internal surfaces of the pump



1. Close the suction connection of the pump with a blind flange.
2. Pour noncorrosive, resin-free oil into the pressure connection until it reaches approx. 2 cm under the pressure flange, while slowly turning the main screw against the direction of rotation.
3. Close the pressure connection of the pump with a blind flange.

After about 6 months storage check the oil level in the pump and top up if necessary

Preserving the external surfaces of the pump



Recommendations:

- Preservative (e.g. Castrol Rustilo DWX 33).
 - Paint or spray the preservative onto all plain and unpainted parts.

At intervals of about six months, check the preservative effect and if necessary repeat preservation.

NOTE

Store the preserved pump in a cool and dry place and do not expose it to direct sunlight.

7.4.1 Removing the preservation

Recommendations:

- Solvent
- Steam-jet cleaning device with wax-dissolving additives



Risk of injury through emitted preservative oil.

- Wear protective clothing during all the work.
- Remove the blind flange with caution to relieve any pressure inside the pump.
- Collect the emitted oil safely and dispose of it in an environmentally compatible manner.



1. Clean the outside of the pump with solvents, if necessary using a steam-jet cleaning device.
2. Remove the blind flange on the pressure side.
3. Drain the pump, collecting the preservative oil in a suitable vessel.
4. Remove the blind flange on the suction side.
5. To remove the residual oil, rinse the pump with the pumped liquid.

7.4.2 Disposing of the pump

Recommendations:

- Solvents or industrial cleaners suitable for the pumped liquid.



Danger of poisoning and damage to the environment from the pumped liquid.

- Wear protective clothing during all the work.
- Collect the discharging pumped liquid and oil and dispose of it in accordance with the locally applicable regulations.
- Neutralize any residues of the pumped liquid.



1. Disassemble the pump.
2. Clean residues of the pumped liquid from the individual parts.
3. Separate sealing elements made of elastomers and ceramics (SiC) from the pump and dispose of them in the residual waste.
4. Recycle metal parts.

8 Installation, removal and connection

8.1 Safety instruction on installation, removal and connection



! NOTE

The following safety instruction must be observed during installation, removal and connection work.

- There is a risk of death for people with pacemakers
 - Under no circumstances may persons with pacemakers perform installation, removal or connection work.

8.2 Installation

! NOTE

Observe the following instructions.

- When selecting the location take the operating limits, NPSH values and ambient conditions into account; refer to [Technical data](#) on page 17.
- The function, safety and service life may not be impaired by humidity, temperature influences or explosive atmospheres.
- During the installation ensure that all the parts of the pump can be accessed easily and that the maintenance work can be carried out easily.

8.3 Installing the pump

Screw pumps can be operated in any installation position. However, we recommend that the pump should not be mounted above the motor since pumped liquid could enter the motor should a leak occur.

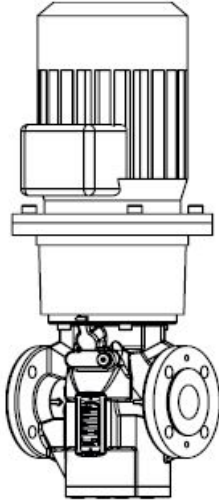

Figure 6: Model ALP vertical mounting

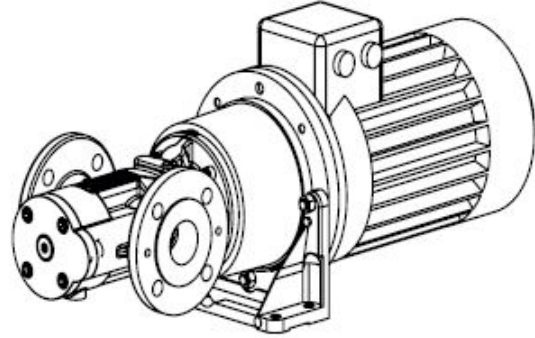

Figure 7: Model ALP Horizontal mounting

Prerequisite:

- The pump connections are to be protected against soiling, for example by using the protective covers mounted in the factory.



CAUTION

Leaking pumped liquid can damage the motor.

- Do not mount the pump above the motor.



CAUTION

Damage to the pump and piping through insufficient fastening.

- Only fasten the pump on a stable load bearing surface.
- Ensure that the fastening elements are tightened sufficiently.



1. Bring the pump into position. Ensure that the flow direction that is marked by arrows on the flanges is correct.
2. Fasten the pump with fastening elements securely to the mounting surface.

8.4 Protect the pump against soiling



CAUTION

Damage through impurities in the pipe system.

- During welding work attach protective covers to the connecting flanges.
- Ensure when welding that welding beads and abrasive dust cannot get into the pipe system and the pump.
- After the connecting work carefully clean the pipe system; refer to

8.4.1 Connecting the pump to the pipe system

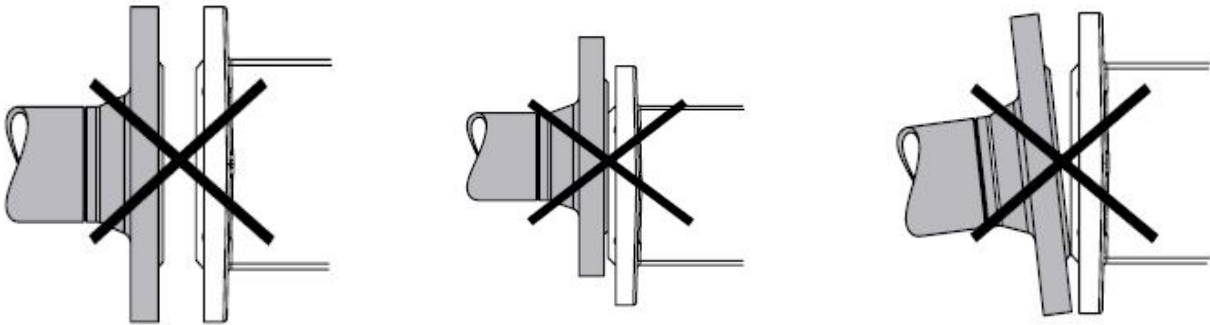

Figure 8: Wrong installation

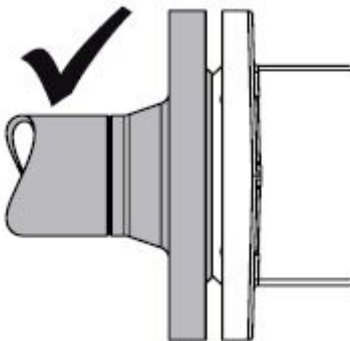

Figure 9: Correct installation

CAUTION

Danger of damage to the device or impaired functionality through mechanical stresses.

- Ensure that the pump mounting on the pipe system is free of mechanical stress.



1. Turn the pump shaft or the fan impeller of the motor. This tests that the pump runs smoothly.
If the pump cannot be turned by hand, remedy the fault before installing the pump.
2. During welding work attach protective covers to the connecting flanges.
3. Place the piping in position and support the weight of the piping.
4. Check the clearance and the angular, vertical and linear offset, adjusting where necessary.
If the screws tighten easily, this is a sure sign that the installation is stress-free.
5. Tighten the connecting screws crosswise with torque.

8.4.2 Connecting the motor



Risk of death resulting from electric shock.

- The motor may only be connected by an authorized electrician.
- Ensure that the power supply is disconnected.
- Earth the pump carefully.



1. Observe the operating instructions of the motor.
2. Ensure that the operating data on the rating plate of the motor agrees with the operating data of the pump and with the local power supply.
3. Connect the motor in accordance with the circuit diagram in the motor terminal box.

8.5 Removing the pump

Recommendations:

- Vessels for leaking pumped liquid



Risk of death resulting from electric shock.

- Ensure that the power supply is disconnected.
- The motor may only be separated from the power supply by an authorized electrician.



Risk of injury through emitted hot, poisonous or corrosive pumped liquid.

- Wear protective clothing during all the work.
- Before carrying out work let the pump cool down to the ambient temperature.
- Ensure that the pump is depressurized.
- Collect the pumped liquid safely and dispose of it in an environmentally compatible manner.



1. Disconnect the motors from the power supply and secure them against being switched back on.
2. Close the pressure-side and suction-side shut-off devices.
3. Empty the pump at the lower point using the draining plug. Collect the emitted pumped liquid in a suitable vessel
4. Loosen the connecting flanges.
5. Loosen the fastening of the pump unit on the mounting surface and dismantle the motor and pump bracket.

9 Operation

9.1 Commissioning



The following safety instruction must be observed during commissioning.

- There is a risk of death for people with pacemakers
 - Under no circumstances may persons with pacemakers perform commissioning work.



The following instructions must always be observed.

- 1 The pump may only be commissioned by authorized qualified personnel.



- 2 Wear protective clothing during all the work.



9.2 Cleaning the pipe system

To protect the pump against soiling the complete pipe system has to be cleaned carefully before initial commissioning of the pump. If the pipe system is to be rinsed using the pump, an additional commissioning filter has to be installed before the pump.

Mesh width of the commissioning filter:

- 0.025 mm



Damage to the pump through additional pressure loss in the commissioning filter.

- 1 Calculate the flow resistance and determine the remaining pump intake.
- 2 Monitor the suction-side pressure.
- 3 Check and clean the commissioning filter regularly.
- 4 Recommended rinsing duration with commissioning filter: 50 -100 hours.



9.3 Filling the pump

There are two possible ways to fill the pump:

1. Pumped liquid already exists at the suction or pressure side: filling via suction or pressure connection.

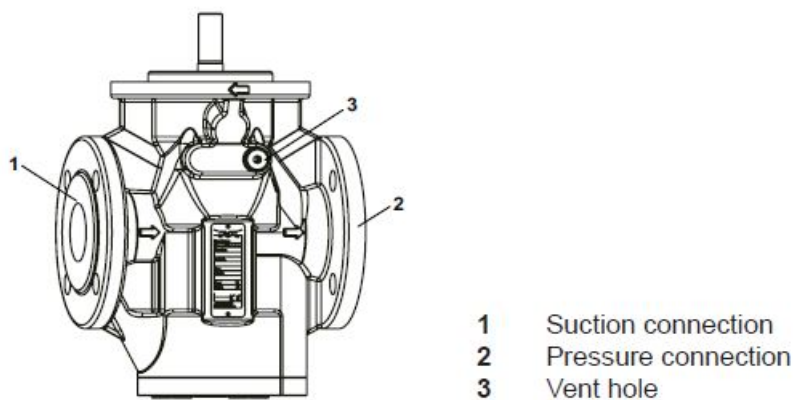

Figure 10: Filling the pump

2. There is no pumped liquid at the suction or pressure side: filling via the vent hole.

9.4 Filling the pump via the suction or pressure connection



Danger of injury or poisoning through dangerous pumped liquids.

Collect the emitted pumped liquid safely and dispose of it in an environmentally compatible manner.

- 1 Open the vent hole **3** so that the air can escape during the filling process.
- 2 Open the suction- or pressure-side shut-off device and fill the pump via the suction or pressure connection until pumped liquid is emitted at the vent hole.
- 3 During the filling process turn the pump shaft or the fan impeller of the motor by hand to speed up the filling process:
 - Filling via suction connection **1**: Turn the pump shaft in the direction of rotation of the motor.
 - Filling via pressure connection **2**: Turn the pump shaft against the direction of rotation of the motor.
- 4 Close the vent hole.



9.5 Checking direction of rotation

The direction of rotation and the flow direction are indicated by arrows on the pump. The direction of rotation of the motor gives the direction of rotation of the pump. That is to say, the fan impeller of the motor must rotate in the direction in which the arrow on the pump is pointing to indicate direction of rotation.

Standard direction of rotation: clockwise (as seen from the drive)

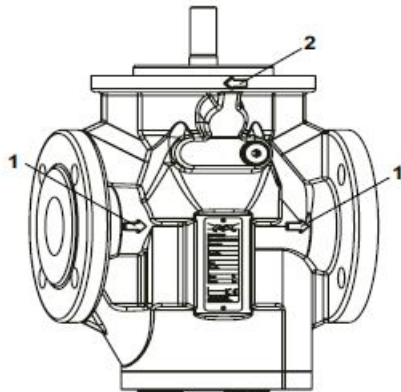

- 1 Arrow for flow direction
2 Arrow for direction of rotation

Figure 11: Identifying direction of rotation and flow direction



Dry running can damage pump equipment.

- Ensure that the pump is filled properly.
- Switch the pump on for a maximum of 1 second and then off again immediately.

- 1 Switch on the power supply and then turn it off again immediately.



- 2 Compare the direction of rotation of the fan impeller with the arrow indicating direction of rotation on the pump flange.

- 3 If the directions do not match, swap over two electrical connection phases. Repeat steps 1 and 2.

9.6 Commissioning the pump

Prerequisites:

- Pump set up and mounted correctly.
- Motor connected correctly.
- Pipe system is free of contamination.
- Commissioning filter mounted, if the pipe system is to be cleaned with the pump.
- Pump is filled.
- Any stop cocks in the suction and pressure line opened.



WARNING

Danger of injury through emitted pumped liquid.

- Wear protective clothing during all the work.
- Ensure that all the connections are connected sealingly.



CAUTION

Dry running can damage pump equipment.

- Ensure that the pump is filled properly.
- If the pump does not deliver after 10 - 15 seconds, abort commissioning.

- 1 Ensure that the pump is filled. In case of doubt pre-lubricate the pump by pouring in liquid via the vent hole; refer to [Filling the pump](#) on page 41.
- 2 Switch on the pump.
The pump will deliver when the pressure on the pressure side of the pump rises or a system-side flow indicator triggers.
- 3 If the pump does not deliver after 10 - 15 seconds of operation, abort initial commissioning, establish the cause of the fault and only then continue the commissioning procedure. Follow the instructions in the fault table; refer to [Troubleshooting](#) on page 64.
- 4 Run the pump for a few minutes to allow the pipe system to vent fully.
The pipe system is fully vented when there is a smooth operating noise and a pressure gauge on the pressure side of the pump shows no more fluctuations.

9.7 Taking pump out of operation



WARNING

Risk of injury or poisoning through emitted pumped liquid.

- Wear protective clothing during all the work.
- Collect the emitted pumped liquid safely and dispose of it in an environmentally compatible manner.



- Carry out the following measures during shutdowns:

Table 13: Measures for operation interruption

| Pump is | Measure |
|-------------------------------|--|
| • Shut down for longer period | Depending on the pumped liquid. |
| • Drained | Close the pressure-side and suction-side stopcocks. |
| • Dismantled | Disconnect the motors from the power supply and secure them against being switched back on. |
| • Stored | Observe measures for storing & preservation; refer to #unique_55 and refer to #unique_56 . |

Table 14: Measures depending on behaviour of the pumped liquid

| Behaviour of the pumped liquid | Duration of the shut down | |
|---|---------------------------|---|
| | Short | Long |
| • Sediment solids | - Rinse the pump. | - Rinse the pump. |
| • Congealed/frozen • No corrosive burden | - Heat or drain the pump. | - Drain the pump. |
| • Congealed/frozen • Corrosive burden | - Heat or drain the pump. | - Drain the pump. - Preserve the pump. |
| • Remains liquid • No corrosive burden | - | - |
| • Remains liquid • Corrosive burden | - | - Drain the pump. - Preserve the pump. |



- Drain the pump via the pressure and suction line and vent screw.

9.8 Recommissioning the pump



Carry out all the steps as for the commissioning process. Refer to [Commissioning](#) on page 39.

10 Maintenance

10.1 Safety instructions on maintenance and repairs

**! DANGER**

There is a risk of death for people with pacemakers.

The following safety instructions must be observed during all work:

- Under no circumstances may persons with pacemakers perform maintenance or repair work.
- All the work may only be carried out by authorized qualified personnel.
- Wear protective clothing during all the work.
- Switch off the motor and secure it against being switched back on.
- Before beginning the work let the pump/ the pump unit cool down to the ambient temperature and remove it from the pipe system.
- Ensure that the pump is depressurized.
- Collect the emitted pumped liquid safely and dispose of it in an environmentally compatible manner.

10.2 Required maintenance

The service life of the pump depends to a great extent on the operating conditions. If the operating limits are observed, refer to *Technical data* on page 17; the pump has a service life of many years.

Signs of progressive wear of individual pump elements:



Table 15: Check table for required maintenance

| Finding | Cause | Remedy |
|---|--------------------------------------|----------------------|
| Increased running noises. | Incipient damage to bearing. | Replace the bearing. |
| Reduction in the flow rate or pressure under constant operating conditions. | Advanced wear of screws and housing. | Replace the pump. |



1. Check the pump visually and acoustically every four weeks.
2. Check for signs of wear as listed in the table above and eliminate the cause.

10.3 Magnetic coupling

The shaft end of the pump is enclosed by a containment can, that is connected air-tight with the motor-side flange of the pump. Special rotors equipped with powerful magnets are used to transfer the torque from the motor to the pump. The inner rotor is fixed at the shaft end and driven from the outer rotor, which in turn is fixed to the shaft of the motor. The torque is thus transferred contact-free by means of magnetic field between the outer and inner rotor.

The pressure discharge of the containment can approximately corresponds to the pressure on the suction side of the pump.

10.4 Ball bearing

The ball bearings used are lubricated by the pumped liquid. Maintenance is therefore not required.

We recommend renewing the ball bearings every two years.

10.5 Replacing the magnetic coupling

Removing the magnetic coupling

10.5.1 Dismantling the outer rotor

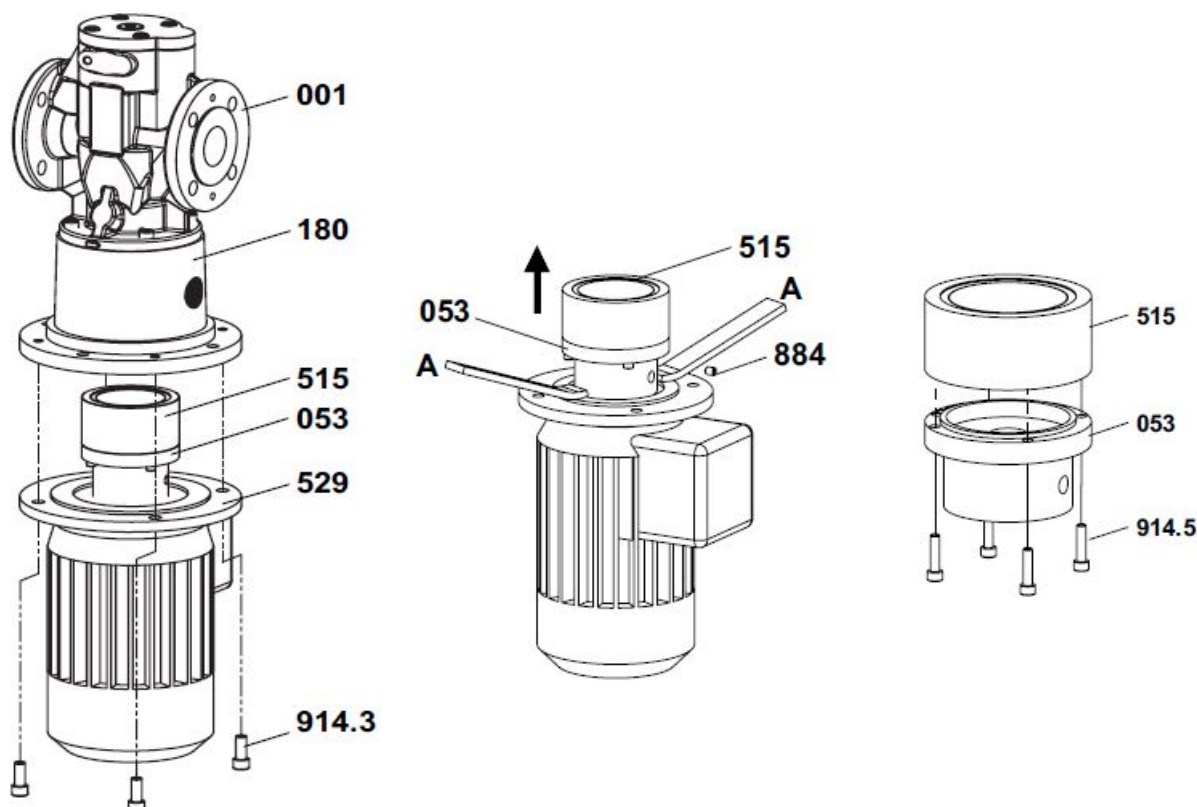

Figure 12: Outer rotor dismantling

| Ref. | Description | Ref. | Description | Ref. | Description |
|------|--------------|------|--------------|-------|----------------|
| 001 | Pump | 515 | Outer rotor | 914.3 | Socket screw |
| 053 | Coupling hub | 529 | Motor | 914.5 | Socket screw |
| 180 | Pump bracket | 884 | Threaded pin | A | Mounting lever |

Recommendations:

- Wrench
- Mounting lever



Risk of injury and/or damage to equipment should the pump/pump unit fall.

- Lift large pumps/pump units using the crane
- Do not stand under raised loads.



- 1 Before dismantling close the suction and pressure connection of the pump with protective covers .
- 2 Loosen the connecting screws **914.3** between the motor **529** and pump bracket **180** and lift the pump with pump bracket from the motor.

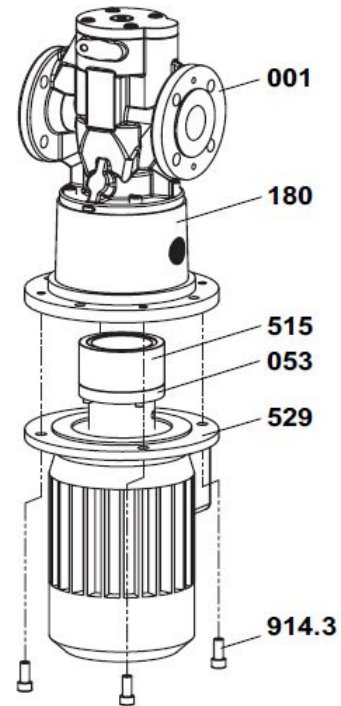

- 3 Loosen the threaded pin **884**. Pull the coupling hub **053** and outer rotor **515** off from the motor shaft using mounting levers **A**

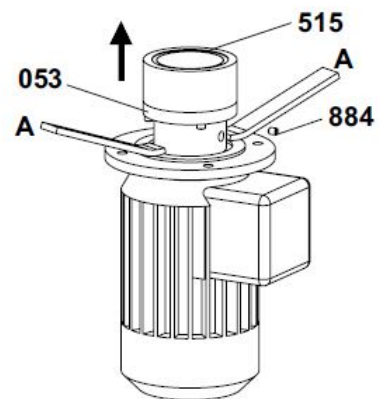

- 4 Loosen the socket screws **914.5** between the coupling hub **053** and the outer rotor **515** .

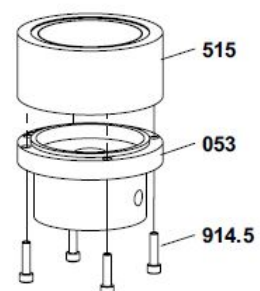

10.5.2 Dismantling the inner rotor

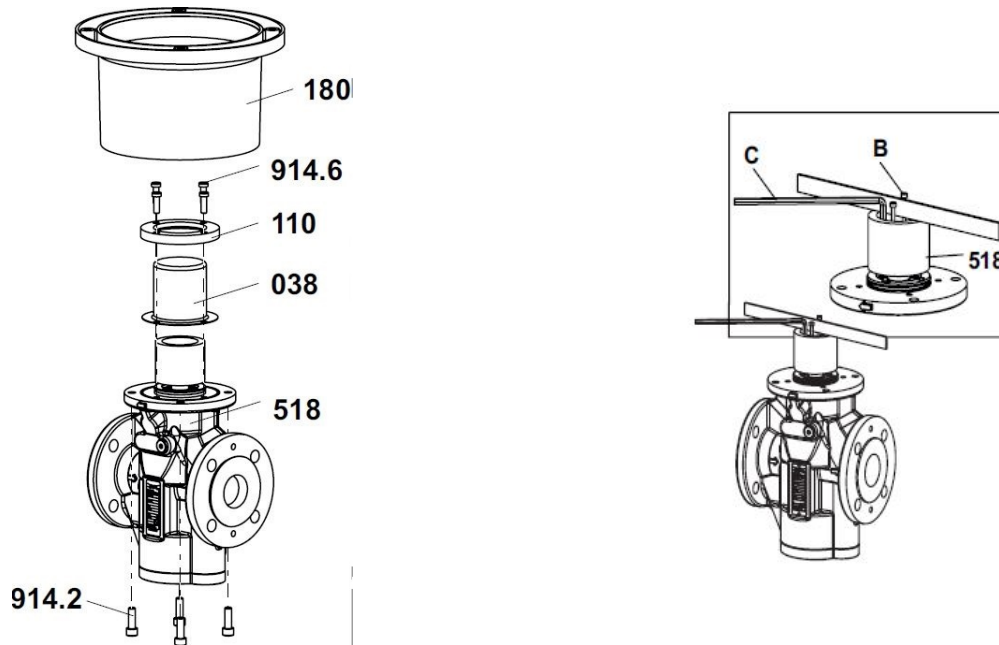

Figure 13: Inner motor dismantling

| Ref. | Description | Ref. | Description | Ref. | Description |
|------|-----------------|-------|--------------|------|---------------------|
| 038 | Containment can | 518 | Inner rotor | B | Anti-rotation screw |
| 110 | Centring flange | 914.2 | Socket screw | C | Allen key |
| 180 | Pump bracket | 914.6 | Socket screw | | |

Recommendations:

- Anti-rotation screw
- Allen key



- 1 Loosen the socket screws **914.2** between the pump and pump bracket **180** and remove the pump bracket.

- 2 Loosen the socket screws **914.6** between the centring flange **110** and pump.
Remove the containment can.

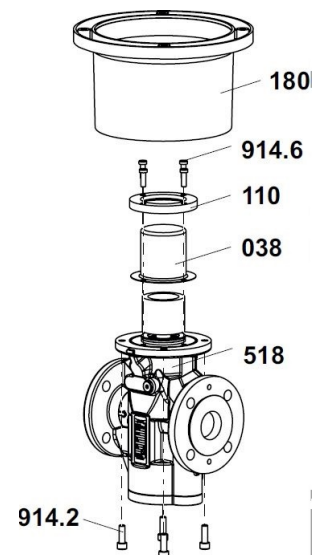

- 3 To replace the inner rotor **518**, insert two anti-rotation screws **B** into the empty threaded holes of the tensioning element to prevent rotation.
Then loosen the screws of the tensioning element and take the inner rotor off the shaft.

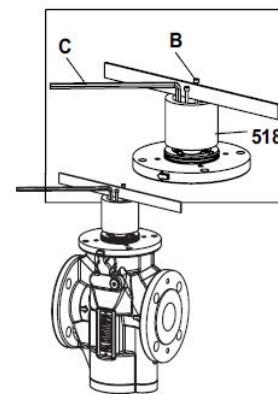

10.6 Installing the magnetic coupling

10.6.1 Mounting the inner rotor

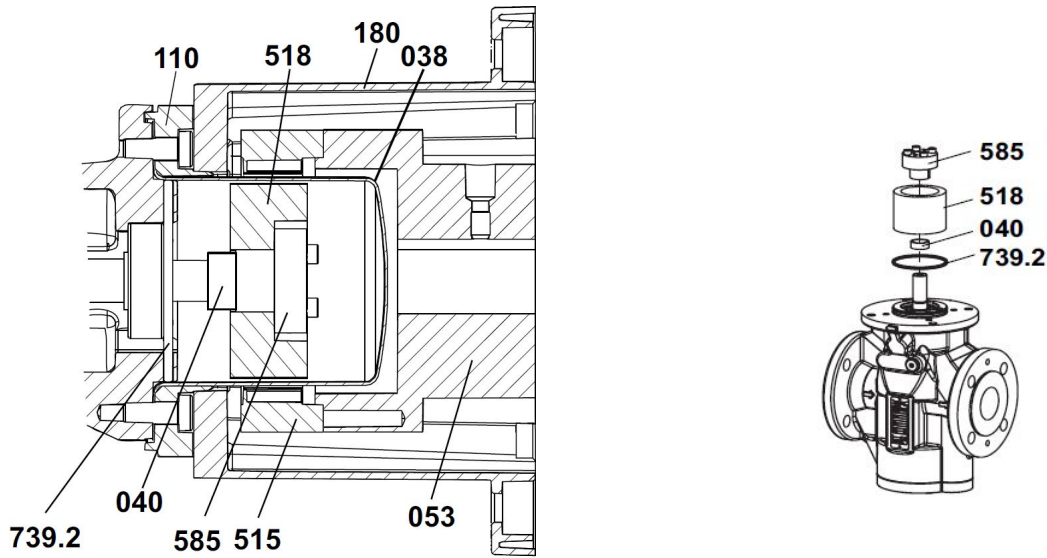
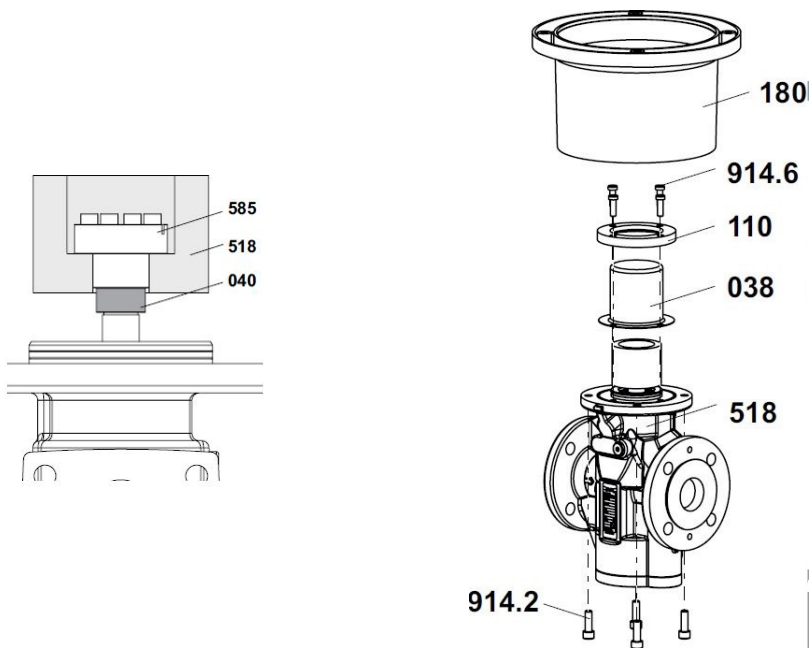

Figure 14: Sectional view magnetic coupling



| Ref. | Description | Ref. | Description | Ref. | Description |
|------|-----------------|-------|--------------------|-------|---------------|
| 038 | Containment can | 518 | Inner rotor | 914.2 | Socket screws |
| 040 | Distance sleeve | 585 | Tensioning element | 914.6 | Socket screws |
| 180 | Pump bracket | 739.2 | O-ring | | |



- 1 Carefully clean the sealing surfaces. Clean and slightly grease the O-ring. Insert the O-ring **739.2** and slide the distance sleeve **040** onto the pump shaft.

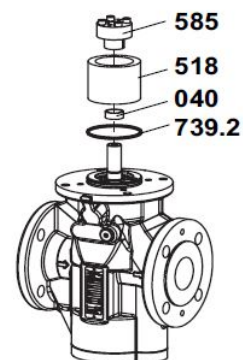

- 2 Clean the contact surfaces of the inner rotor **518** carefully. Oil the tensioning element **585** slightly.

NOTE

Use only oil without molybdenum sulphide additive, eg.: Multifunctional spray WD-40 .

- 3 Turn out the screws of the tensioning element a few turns by hand. Insert the tensioning element in the inner rotor.
- 4 Place the inner rotor with pre-mounted tensioning element on the pump shaft and tighten the screws of the tensioning element crosswise by hand.

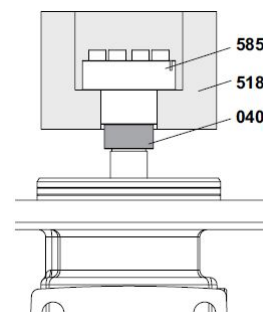

- 5 Check the position of the tensioning element: the tensioning element has to lie on the distance sleeve and inner rotor.

Otherwise loosen the screws again and re-align the tensioning element.

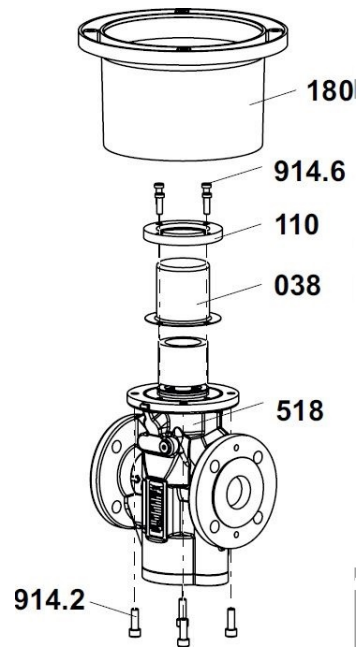

- 6 If the position is correct, first tighten the screws of the tensioning element with half the tightening torque crosswise.

Subsequently tighten them several times crosswise with the **full** tightening torque until no screw can be turned any further.

NOTE

The screws are only tightened correctly when they can no longer be turned while being tightened with the full torque.

- 7 Press the containment can 038 with the centring flange 110 onto the pump flange and tighten the connecting screws 914.6,

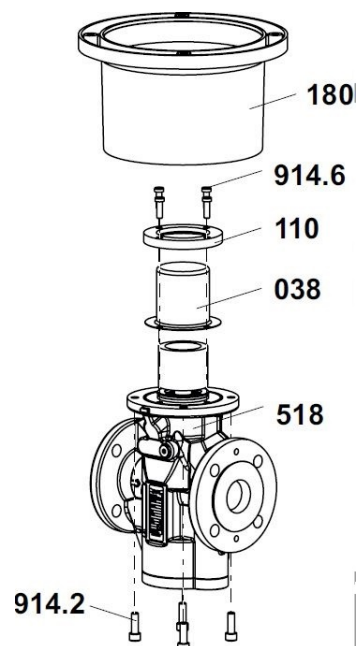

-
- 8 Place the pump bracket **180** on the pump and tighten the socket screws **914.2** .
-

10.6.2 Mounting the outer rotor

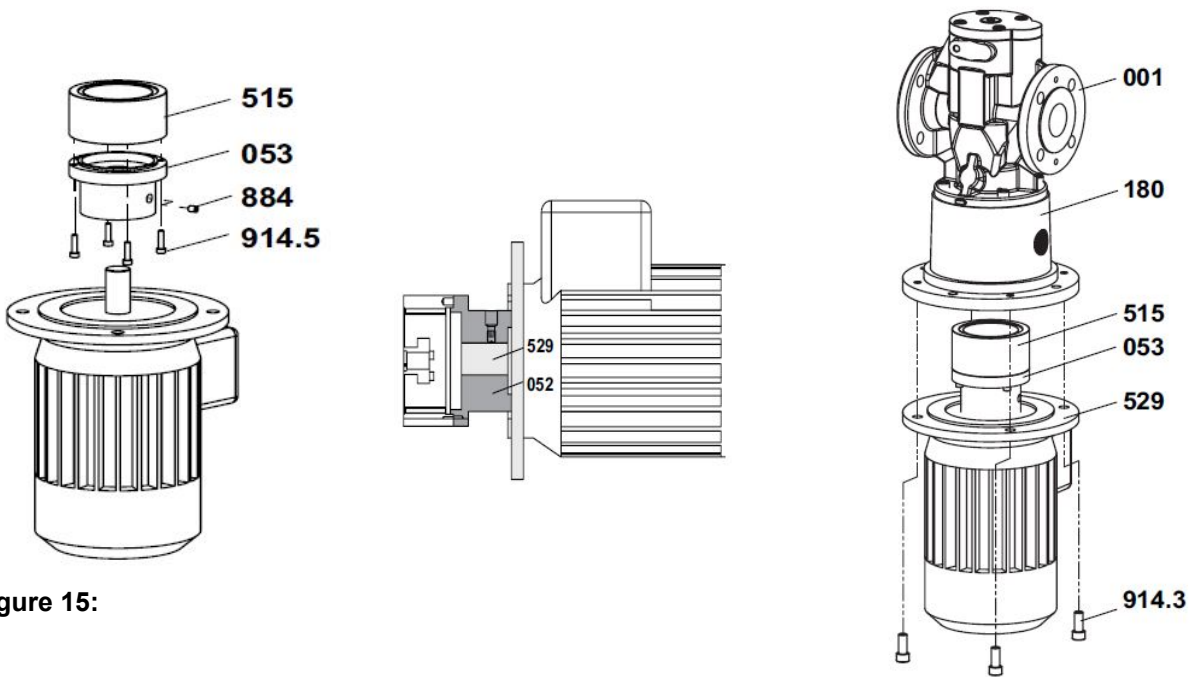
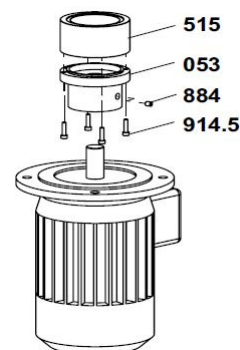

Figure 15:

| Ref. | Description | Ref. | Description | Ref. | Description |
|------|--------------|------|--------------|-------|--------------|
| 001 | Pump | 515 | Outer rotor | 914.5 | Socket screw |
| 053 | Coupling hub | 529 | Motor | 914.3 | Socket screw |
| 180 | Pump bracket | 884 | Threaded pin | | |



- 1 Carefully clean the outer rotor **515** with compressed air. Tighten the connecting screws **914.5** of the outer rotor and coupling hub **053** with torque.
- 2 Clean the shaft end of the motor and apply lubricant.
- 3 Place the coupling hub with outer rotor onto the shaft of the motor. Heating up to approx. 80 °C facilitates mounting. Tighten the threaded pin **884**.



- 4 The shaft end of the motor must be flush with the front surface of the coupling hub.

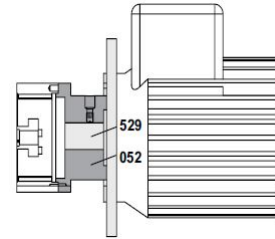

- 5 Place the pump with pump bracket on the motor.
Do not use force and ensure that the outer rotor does not strike the containment can.

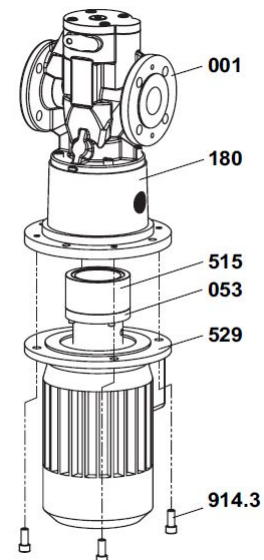

- 6 Tighten the connecting screws **914.3** of the motor and pump bracket.
Do not remove the protective covers until just before reconnecting the pump to the pipe system.

10.7 Replacing the ball bearing

10.7.1 Removing the ball bearing

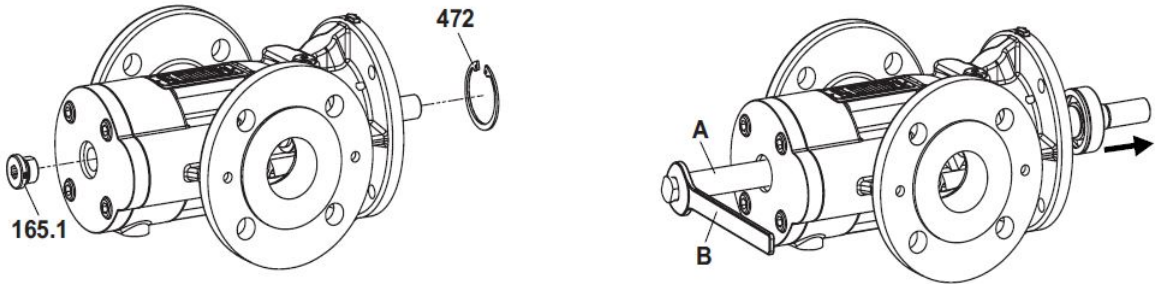
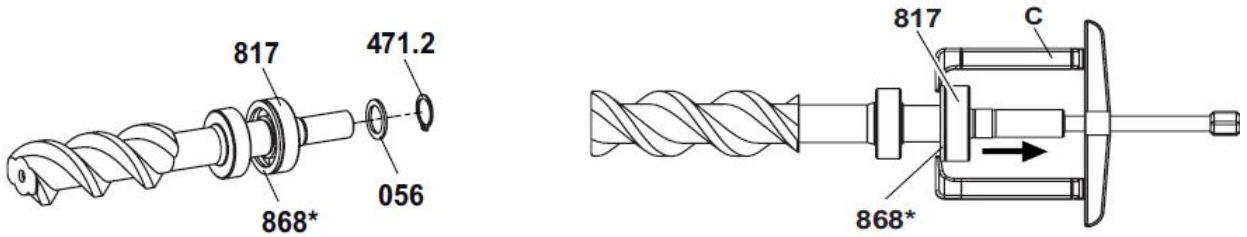

Figure 16:



| Ref. | Description | Ref. | Description | Ref. | Description |
|--------|-----------------|------|-----------------|------|------------------|
| 056(*) | Supporting ring | 472 | Circlip | A | Disassembly tool |
| 165.1 | Screw plug | 817 | Ball bearing | B | Open-end wrench |
| 471.2 | Circlip | 868* | Supporting ring | C | Extractor |

* Only for sizes 100 - 115.

Recommendations:

- Disassembly tool
- Open-end wrench
- Extractor



- 1 Remove the circlip **472** and screw plug **165.1**.

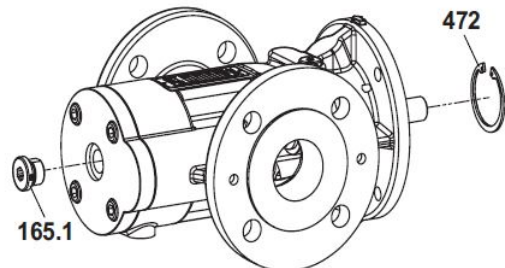

- 2 Screw in the disassembly tool **A** by using the open-end wrench **B**.
The main screw will be pressed out of the pump housing.

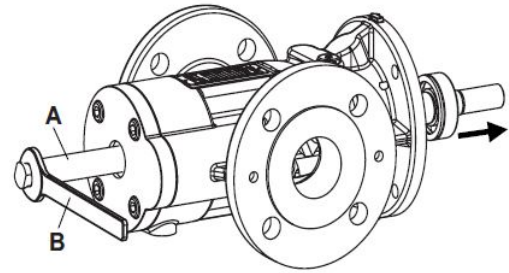

- 3 Remove the circlip **471.2** and supporting ring **056**.

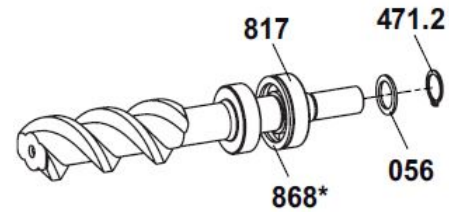

- 4 Pull the ball bearing **817** from the main screw using a suitable extractor **C**.

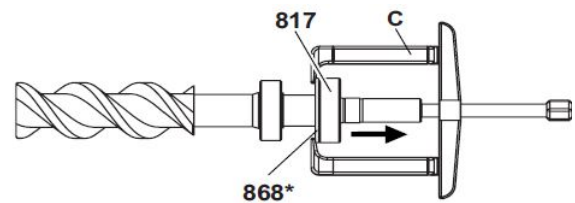

10.7.2 Installing the ball bearing

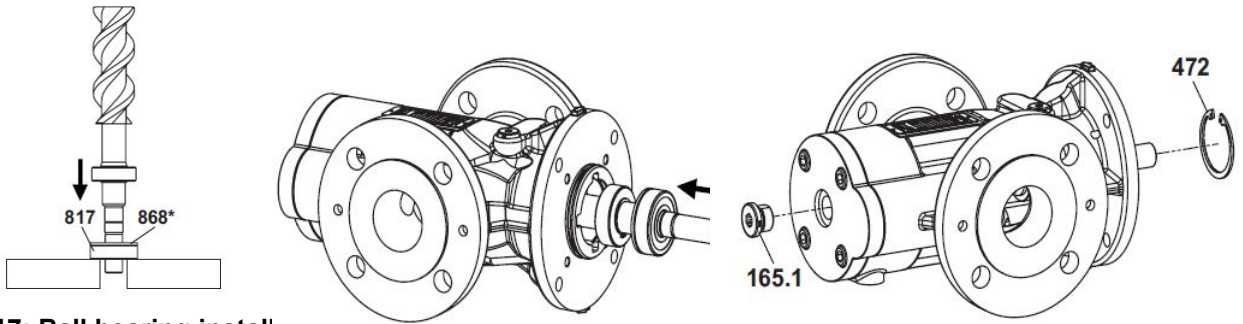
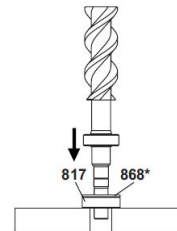

Figure 17: Ball bearing installation

| Ref. | Description | Ref. | Description |
|-------|-----------------|------|-----------------|
| 056 | Supporting ring | 472 | Circlip |
| 165.1 | Screw plug | 817 | Ball bearing |
| 471 | Circlip | 868* | Supporting ring |

* Only for sizes 100 - 115.

- 1 Clean the fitting surfaces and the main screw. Grease the main screw slightly.
- 2 Push the supporting ring 868* onto the main screw, press the ball bearing 817 onto the main screw.



- 3 Mount the supporting ring 056 and circlip 471. Slide the main screw with premounted ball bearing into the pump housing until the main screw engages into the idle screws. In doing so turn the main screw.

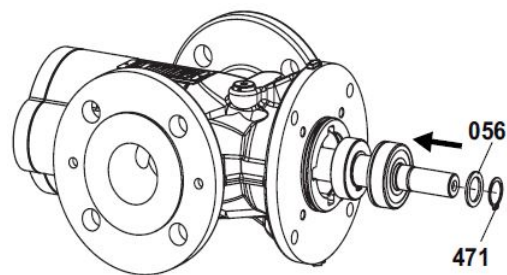

- 4 Mount the screw plug 165.1 and circlip 472.

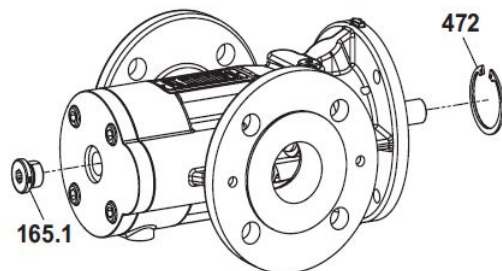

11 Troubleshooting

11.1 Possible faults

Faults can have different causes. The following tables list the symptoms of a fault, the possible causes and measures for elimination.



| Fault | Cause/Remedy |
|---------------------------|--|
| • No pump suction | 1, 2, 3, 4, 5, 6, 7, 8, 28 |
| • Delivery rate too low | 2, 3, 4, 9, 10, 11, 12, 13, 14, 15, 16, 17 |
| • Pump runs noisily | 2, 3, 4, 6, 10, 11, 13, 15, 18, 19, 20, 21 |
| • Motor overload | 9, 11, 14, 21, 22 |
| • Uneven delivery rate | 2, 3, 4, 6, 11, 13, 15, 16 |
| • Magnetic coupling leaks | 24, 25 |
| • Pump has seized up | 26, 27 |

11.2 Troubleshooting



Table 16: Fault table

| No. | Cause | Remedy |
|-----|---|--|
| 1 | Pump suction pipe closed. | - Check shut-off devices in the suction pipe and open them, if necessary. |
| 2 | Suction valve or pipe obstructed. | - Check the suction valve and pipe for clear passage. |
| 3 | Suction pipe or shaft seal leaks. | - Check suction pipe or shaft seal for leaks. Pay particular attention to leakage at valves and connection points. If necessary, replace parts. |
| 4 | Suction head too high. | - Reduce difference of level -or- - Reduce pipe length -or - Increase pipe diameter -or - Heat the liquid to reduce viscosity -or - Install suction filter with greater mesh width. Ensure that the permissible mesh width is not exceeded; refer to <i>Cleaning the pipe system</i> on page 40. |
| 5 | Level of liquid in the intake container too low. | - Top up the pumped liquid. |
| 6 | Dirty filter/strainer. | - Clean the filter/strainer. |
| 7 | Pump intake capacity reduced by inadequate wetting. | - Fill pump with liquid. |
| 8 | Incorrect pump direction of rotation. | - Carry out the electrical connection so that the direction of pump rotation matches that of the arrow on the flange cover. |
| 9 | Differential pressure too high. | - Check the system and reduce the differential pressure. |
| 10 | Magnetic coupling broken off. | - Stop the pump immediately and restart it. - Avoid excessive differential pressures. - At repeated occurrence check whether pump has seized up. |
| 11 | Viscosity of the pumped liquid too high. | - Increase the temperature of the liquid -or - Reduce the rotation speed. |
| 12 | Viscosity of the pumped liquid too low. | - Reduce the temperature of the liquid -or - Increase the rotation speed. |
| 13 | Airlock or gas in the liquid. | - Test the pipe system for ingress of air and replace parts if necessary. - Reduce the suction head -or - Increase the feed pressure. |
| 14 | Motor running at wrong voltage or frequency. | - Ensure that the motor voltage and frequency match the operating voltage. - Compare the rotation speed of the motor with the pump rating plate. If the data does not match, adjust the rotation speed of the motor. |
| 15 | Overflow valve opens during normal operation. | - Set opening pressure above value of operating pressure. |
| 16 | Overflow valve leaks. | - Clean the overflow valve and if necessary, reset. |

| No. | Cause | Remedy |
|-----|---|---|
| 17 | Advanced wear of rotating pump components. | - Check screw set and housing and replace if necessary. |
| 18 | Pump distorted. | - Support the weight of the piping. - Loosen pipe connections and mount stress-free; refer to Installation on page 33. |
| 19 | Resonance in the system. | - Provide a flexible bearing arrangement -or - Make the connections with hoses. |
| 20 | Speed of flow in suction or pressure line too high. | - Set the flow speed in the suction line so that it does not exceed 1 m/s. - Set the flow speed in the pressure line so that it does not exceed 3 m/s. |
| 21 | Ball bearing damaged. | - Replace the ball bearing; refer to Replacing the ball bearing on page 60. |
| 22 | Lack of lubrication or foreign bodies have caused superficial damage to rotating pump components. | - Check the screw set and the housing. If necessary, replace pump with free shaft end. |
| 23 | Thermal or chemical loading of elastomer seals exceeded. | - Check the maximum operating temperature. - Check the resistance of the elastomers with regard to the pumped liquid. |
| 24 | Containment can damaged by abrasive liquids. | - Replace the containment can and O-ring; refer to Replacing the magnetic coupling on page 49. |
| 25 | Foreign bodies in the pump. | - Dismantle the pump and clean it. - Smooth the superficial damage to the housing and the rotating parts with an oilstone. If necessary, replace the pump with free shaft end. |
| 26 | Dry running can damage the pump. | - Dismantle the pump and clean it. - Smooth the superficial damage to the housing and the rotating parts with an oilstone. If necessary, replace pump with free shaft end. - When resuming operation, take action to prevent dry running; refer to Recommissioning the pump on page 46. |
| 27 | Pump does not vent. | - Vent the pressure line at the highest point. |

12 Spare Parts

12.1 ALP magnetic coupling spare parts

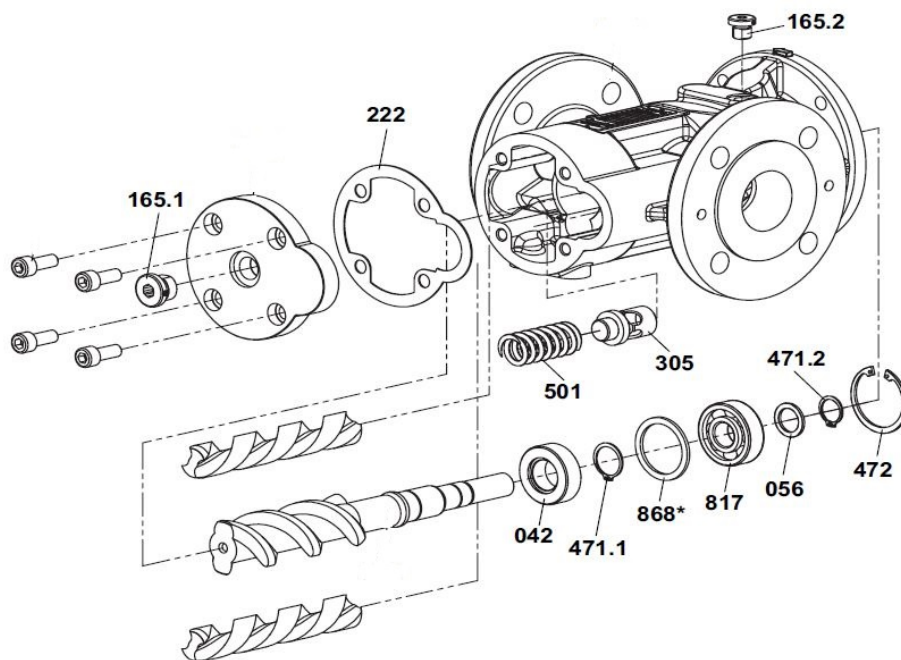
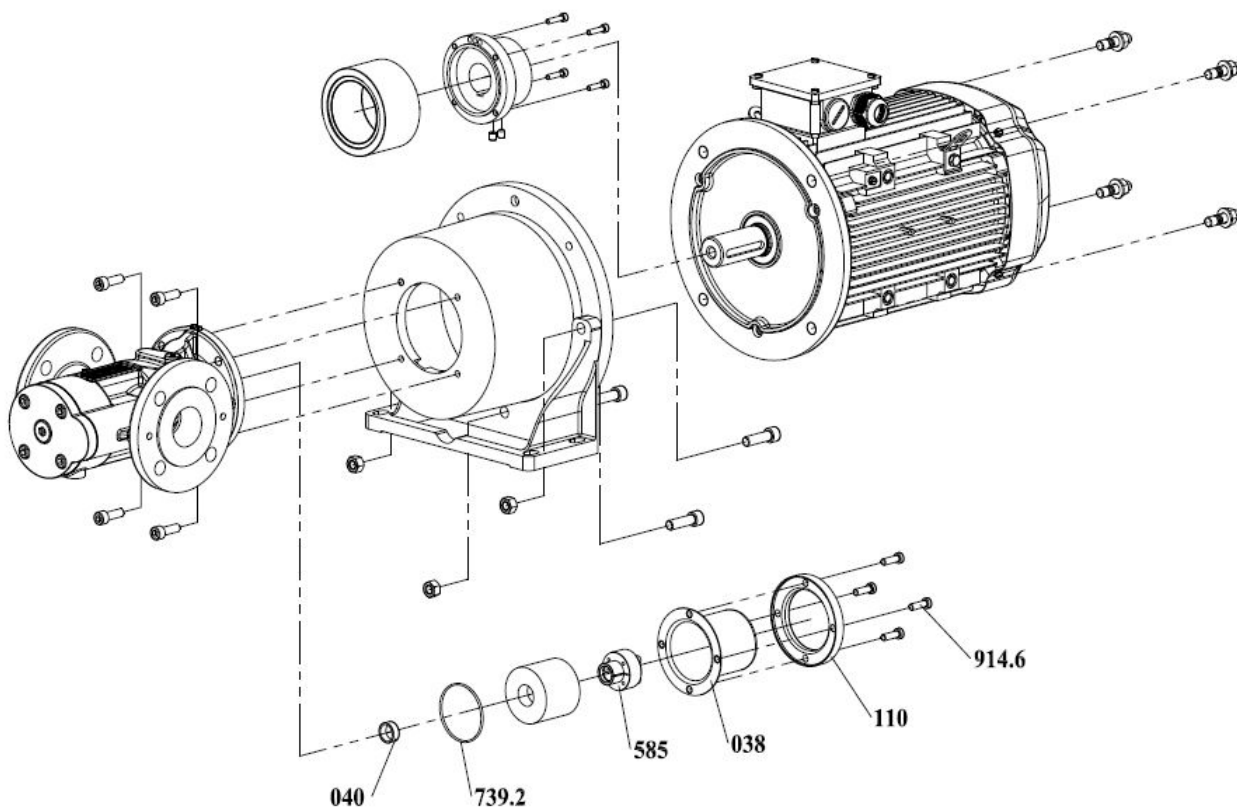

Figure 18: ALP 0100–0280: spare parts general drawing



12.2 ALP Magnetic coupling - Maintenance kit

12.2.1 ALP 0100-0115 Magnetic coupling - Maintenance kit

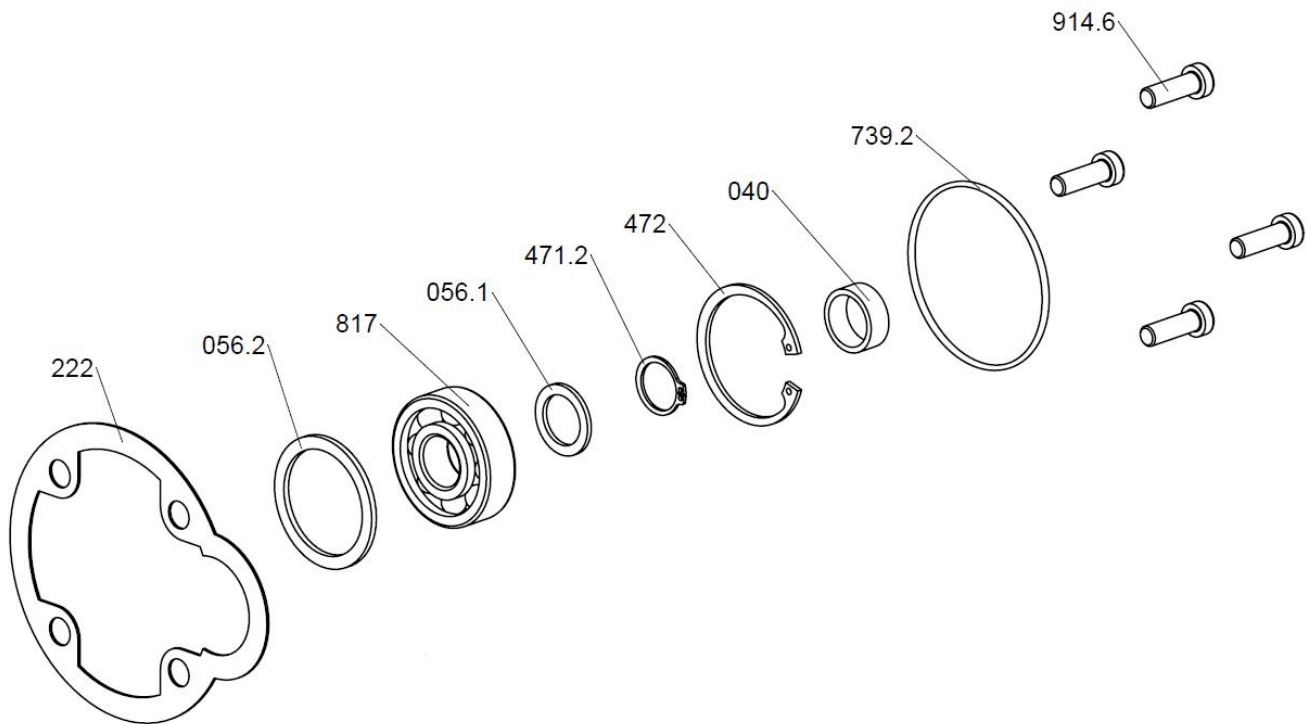

Figure 19: ALP 0100-0115 Magnetic coupling – Maintenance kit 9014380 83

Table 17: ALP-0100-0115, Magnetic coupling, Size 75, Nm 30, IEC 132

| ALP 0100-0115 Magnetic coupling | | | |
|---------------------------------------|----------|--|--------------|
| Denomination | Qty. | Dimensions | Pos. no. |
| Maintenance kit MAG 9014380 83 | 1 | | |
| Distance sleeve | 1 | D 20.5xD 25.0x9.5lg | 040 |
| Supporting ring | 1 | S 20x28x2.0 | 056.1 |
| Supporting ring | 1 | S 42x52x2.5 | 056.2 |
| Flat gasket | 1 | SIL C 4400 | 222 |
| Circlip | 1 | 20x1.20 | 471.2 |
| Circlip | 1 | 52x2.00 | 472 |
| O-ring | 1 | 68.00x2.50 | 739.2 |
| Ball bearing | 1 | 6304, 20x52x15 C4 | 817 |
| Socket screw | 4 | M 8x25 | 914.6 |
| Disassembling tool | 1 | Refer to <i>Required tool for maintenance work</i> on page 76 for details. | |

12.2.2 ALP 0165-0280 Magnetic coupling - Maintenance kit

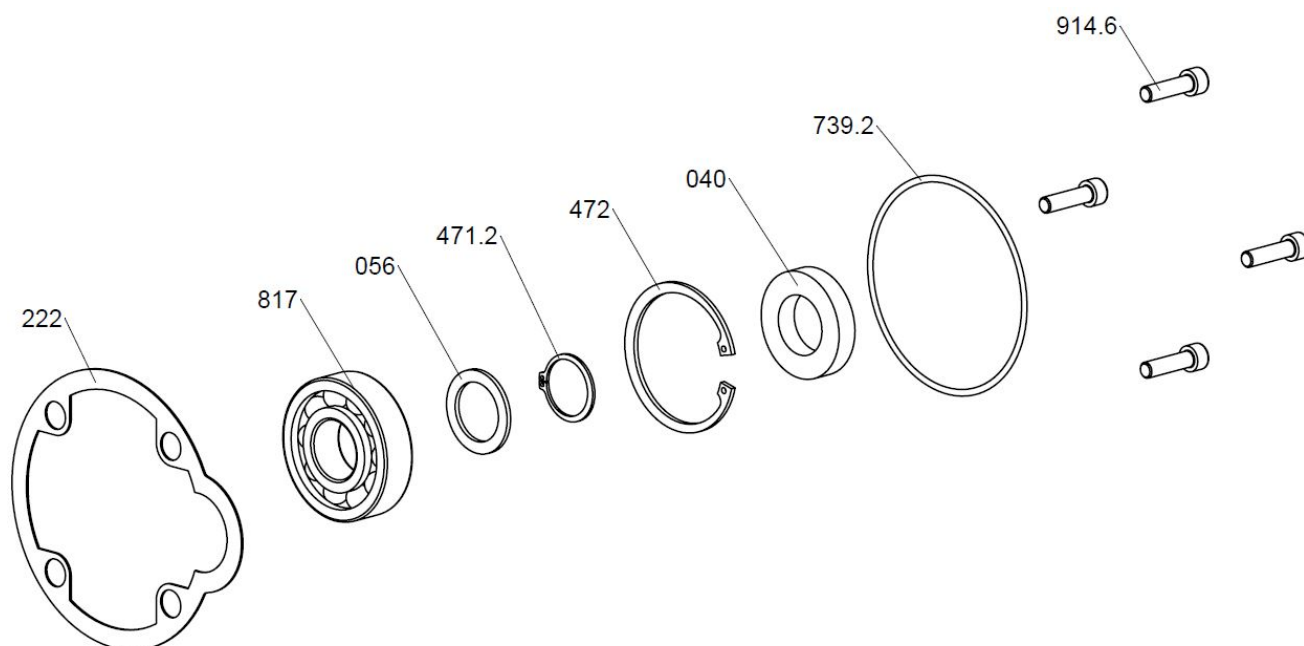
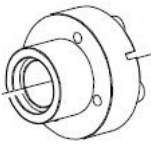

Figure 20: ALP 0165-0280 Magnetic coupling – Maintenance kit 9014380 84

Table 18: 0165-0280, Magnetic coupling, Size 75, Nm 60, IEC 132+160

| ALP 0165-0280 Magnetic coupling | | | |
|---------------------------------------|----------|---|--------------|
| Denomination | Qty. | Dimensions | Pos. no. |
| Maintenance kit MAG 9014380 84 | 1 | | |
| Distance sleeve | 1 | D 30.3xD 52.0x11.0lg | 040 |
| Supporting ring | 1 | S 30x42x2.5 | 056 |
| Flat gasket | 1 | SIL C 4400 | 222 |
| Circlip | 1 | 30x1.50 | 471.2 |
| Circlip | 1 | 72x2.50 | 472 |
| O-ring | 1 | 105.00x2.50 | 739.2 |
| Ball bearing | 1 | 6306, 30x72x19 C4 | 817 |
| Socket screw "old design ALP-__-D" | 4 | M 10x35 | 914.6 |
| Socket screw "new design ALP-__-M" | 4 | M 8x30 | 914.6 |
| Disassembling tool | 1 | Refer to Required tool for maintenance work on page 76 for details. | |

12.3 Tensioning element

| Tensioning element, Pos. 585 | | | |
|---|--------------------------------------|------------|-----|
|  | Pump type | Part no. | Qty |
| | ALP 0100-0115, Magnetic coupling, | 9012876 02 | 1 |
| | ALP 0165-0280, Magnetic coupling | 9012876 03 | 1 |

12.4 Valve body (cone)

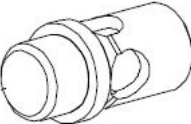
| Valve body (cone), Pos. 305 | | | |
|---|-------------------------------------|------------|-----|
|  | Pump type | Part no. | Qty |
| | ALP 0100-0115, Magnetic coupling | 9012877 03 | 1 |
| | ALP 0165-0280, Magnetic coupling | 9012877 04 | 1 |

12.5 Cylindrical spring

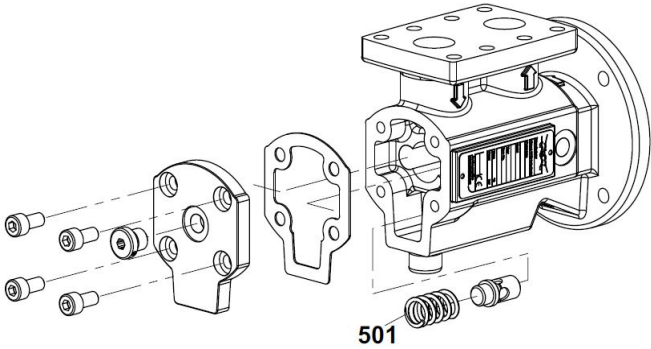
| Cylindrical spring, Pos. 501 | | | |
|---|-------------------------------------|------------|-----|
|  | Pump type | Part no. | Qty |
| | ALP 0100-0115, Magnetic coupling | 9014370 06 | 1 |
| | ALP 0165-0280, Magnetic coupling | 9014370 08 | 1 |

12.6 Containment can

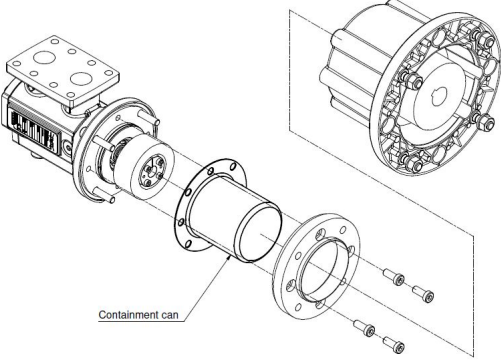
| Containment can, Pos. 038 | | | |
|---|-------------------------------------|------------|-----|
|  | Pump type | Part no. | Qty |
| | ALP 0100-0115, Magnetic coupling | 9043567 02 | 1 |
| | ALP 0165-0280, Magnetic coupling | 9043567 03 | 1 |

12.7 Screw plug for ALP magnetic coupling



Figure 21: Srew plug

Table 19: Screw plug for ALP magnetic coupling

| Pump type ALP MAG | Screw plug | Part no. | Pos. no. |
|------------------------------|-------------------|-----------------|-----------------|
| 0100 | DVV 38 | 9046911 01 | 165.1 |
| 0115 | DVV 36 | 9046911 02 | 165.2 |
| 0165 | DVV 38 | 9046911 01 | 165.1 |
| 0215 | DVV 36 | 9046911 02 | 165.2 |
| 0230 | | | |
| 0280 | | | |

13 Appendix

13.1 General drawings

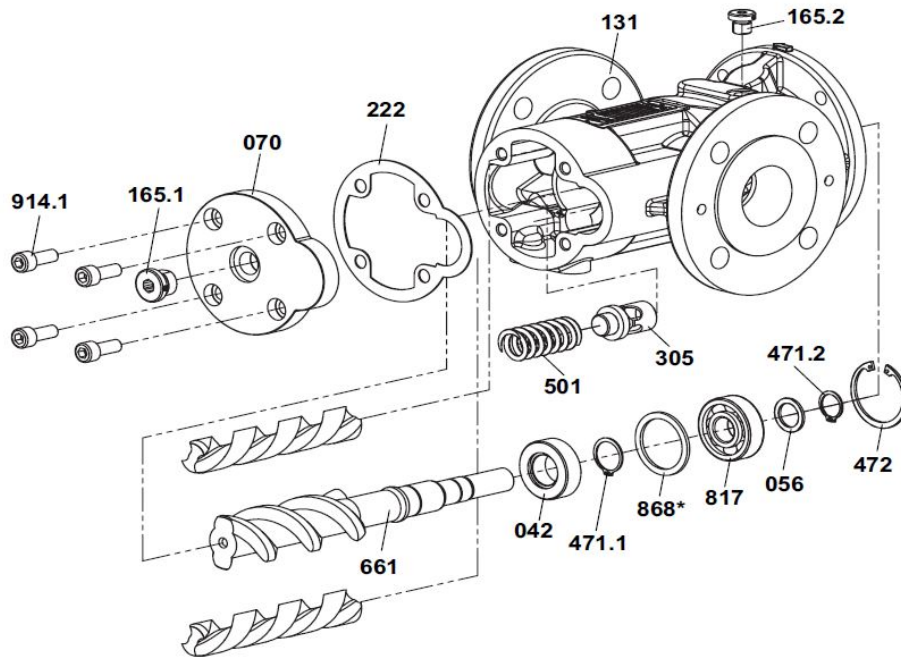

Figure 22: ALP 0100–0280

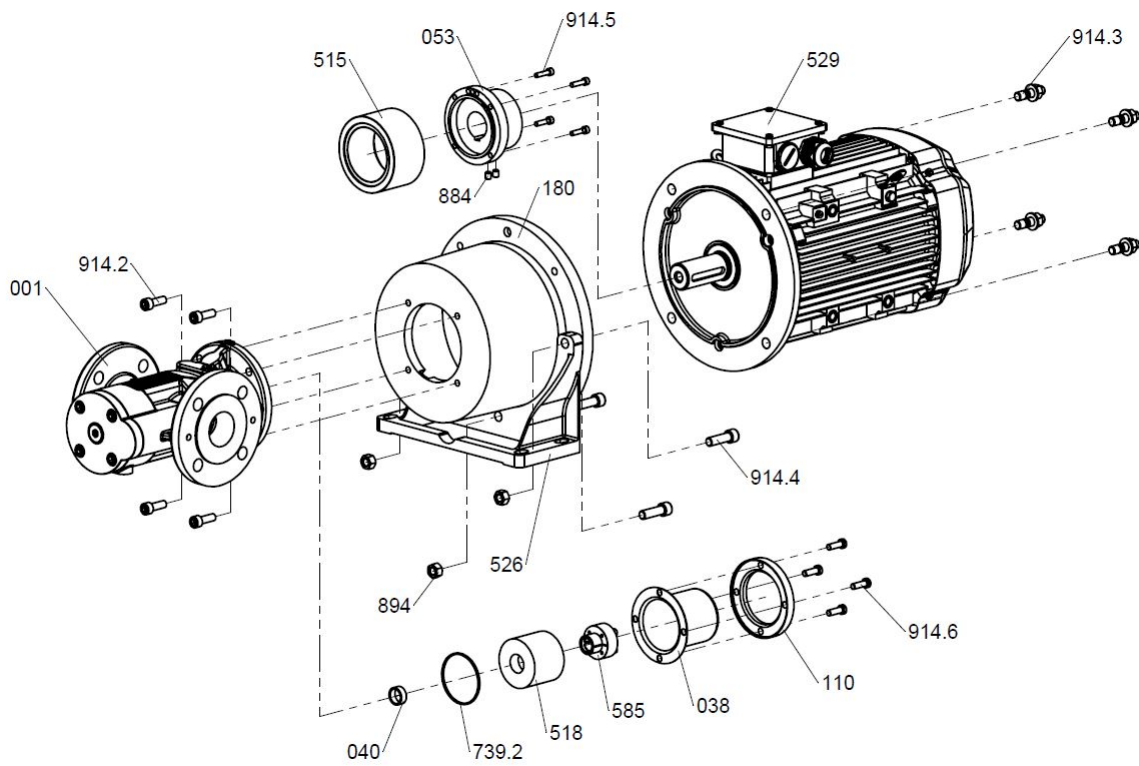

Figure 23: Completion magnetic coupling ALP 0100–0280

13.2 Parts table

Table 20: Parts numbers

| Pos. no. | Denomination | Note |
|----------|--------------------|---|
| 001 | Pump | |
| 038 | Containment can | |
| 040 | Distance sleeve | |
| 042 | Balancing cylinder | |
| 053 | Coupling hub | |
| 056 | Supporting ring | |
| 070 | End cover | |
| 131 | Pump housing | |
| 165.1 | Screw plug | |
| 165.2 | Screw plug | |
| 180 | Pump bracket | |
| 222 | Flat gasket | |
| 305 | Valve body | |
| 471.1 | Circlip | |
| 471.2 | Circlip | |
| 472 | Circlip | |
| 501 | Spring | |
| 515 | Outer rotor | |
| 518 | Inner rotor | |
| 526 | Pump bracket foot | |
| 529 | Motor | |
| 585 | Tensioning element | |
| 661** | Screw set | ** In case of wear of the screw set we recommend to replace the pump. |
| 739.2 | O-ring | |
| 817 | Ball bearing | |
| 868* | Supporting ring | * Only for sizes 100 - 115 |
| 884 | Threaded pin | |
| 894 | Hexagon nut | |
| 914.1 | Socket screw | |
| 914.2 | Socket screw | |
| 914.3 | Socket screw | |
| 914.4 | Socket screw | |
| 914.5 | Socket screw | |
| 914.6 | Socket screw | |

13.3 Tightening torques

Table 21: Tightening torques

| Tightening torque [Nm] for screws with metric threads + head contact surfaces | | | | | | | | with thread measured in inches | |
|---|-----|------|------------|----------------------|------------------|----------------------------------|-------------------|---|------------------------------|
| Thread | 8.8 | 10.9 | 8.8 + Alu* | + wedge lock washers | | Stainless steel screws A2 and A4 | | Screw plugs with elastomer seal | |
| | | | | 8.8 | Rust-proof A4-70 | Property class 70 | Property class 80 | Thread | Galvanized + stainless steel |
| 1.5 | - | 1.2 | 1.5 | 1.1 | - | - | | G 1/8" | 13 |
| 2.9 | 4.1 | 2.3 | 3 | 2 | - | - | | G 1/4" | 30 |
| 6.0 | 8.0 | 4.8 | 6.0 | 3.9 | 3.5 | 4.7 | | G 3/8" | 60 |
| 9.5 | 14 | 7.6 | 10.3 | 6.9 | 6 | 8 | | G 1/2" | 80 |
| 23.1 | 34 | 18.4 | 25 | 17 | 16 | 22 | | G 3/4" | 120 |
| 46 | 68 | 36.8 | 47 | 33 | 32 | 43 | | G 1" | 200 |
| 80 | 117 | 64 | 84 | 56 | 56 | 75 | | G 1 1/4" | 400 |
| 127 | 186 | 101 | 133 | 89 | - | - | | G 1 1/2" | 450 |
| M 16 | 194 | 285 | 155 | 204 | 136 | 135 | 180 | | |
| M 18 | 280 | 390 | 224 | 284 | 191 | - | - | | |
| M 20 | 392 | 558 | 313 | 399 | 267 | 280 | 370 | * Reduced tightening torque when screwing into aluminium. | |
| M 24 | 675 | 960 | 540 | 687 | 460 | 455 | 605 | | |

Table 22: Tightening torques for fixing screws of conical hub connectors

| Tightening torques [Nm] for fixing screws of conical hub connectors | |
|---|------|
| Thread | 12.9 |
| M 3 | 1.8 |
| M 4 | 4.5 |
| M 6 | 16 |
| M 8 | 37 |
| M 10 | 73 |
| M 12 | 126 |

13.4 Required tool for maintenance work

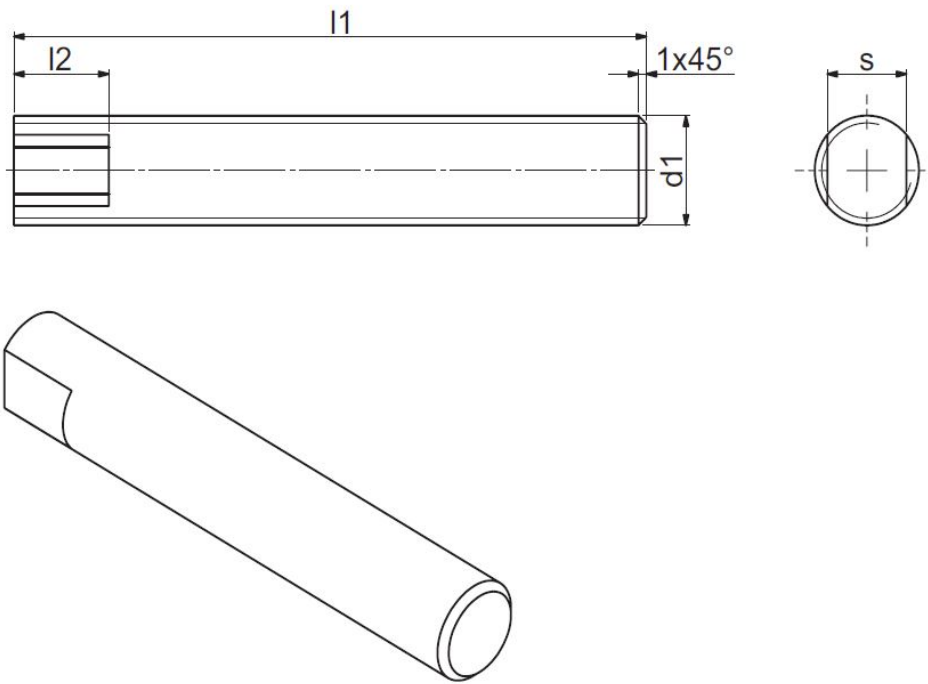

Figure 24: Disassembly tool

Table 23: Disassembly tool dimensions

| Disassembly tool dimensions [mm] | | | | |
|----------------------------------|--------|-----|----|----|
| Size | d1 | l1 | l2 | s |
| 100 – 280 | G 1/2" | 130 | 15 | 17 |

14 EC Declaration of conformity

EC Declaration of conformity

12 Appendix

EC Declaration of conformity



The designating company

Alfa Laval Kolding A/S

Company name

Albuen 31, DK-6000 Kolding, Denmark

Address

+45 79 32 22 00

Phone No.

hereby declares that

Denomination: Three-Screw Pump
 Type: ALP
 Date: 2013-04-01

Is in conformity with

- Machinery Directive 2006/42/EC

and furthermore declares that if motorised the following applicable directives have been used

- Directive 2006/95/EC on low voltage
- EMC Directive 2004/108/EC

The technical construction file for this machinery has been drawn up. The signer of this declaration is authorized to compile the technical file.

Manager, Product Center Fluid Handling

Title

Bjarne Søndergaard

Name

A handwritten signature in black ink, appearing to read 'B. Søndergaard'.

Alfa Laval Kolding A/S

Company

Signature